



**SYCARD**  
TECHNOLOGY

---

# ***PCCproto 200 User's Manual***

***M200012-00  
April 1996***

***Preliminary***

***Sycard Technology  
1180-F Miraloma Way  
Sunnyvale, CA 94086  
(408) 749-0130  
(408) 749-1323 FAX  
<http://www.sycard.com>***

## 1.0 Introduction

The PCCproto 200 kit is designed to quickly prototype and evaluating a multifunction design based on the National Semiconductor PCM16C02 interface chip. The PCM16C02 is a full 16 bit interface solution for single or multiple function designs.

The PCCproto 200 is based on Sycard Technologies PCCproto 150 PC Card prototype platform. Designed specifically for the PC Card development environment, the PCCproto 200 provides support for a wide variety of high-pincount, tight pin-pitch devices.

### *PCCproto 200 Key Features:*

- Integrated National Semiconductor PCM16C02 Multifunction interface chip
- On-board serial EEPROM for CIS storage
- On-board oscillator
- Current Protection Device protect host system
- Plug-in Daughter boards support a wide variety of high pin count devices
- Support 4 types of I/O connectors
- Multilayer construction
- LEDs indicate Vcc levels
- Includes 3 general purpose daughter boards
- PCCswap switch simulates card insertion/removal

## 1.1 Specifications

### **Electrical**

Power	3.3V/5.0V Operation
Current Consumption	1A max.

### **Mechanical**

Width	7.7" (19.6 cm)
Length	11.7" (29.7 cm)
Thickness	0.7" (18mm)
Weight	8 oz

## 1.2 Packing List

The PCCproto 200 contains a number of items designed to help in your prototype design.

- PCCproto 200 Main Prototype Board
- PCCproto 210-1 PCM16C02 Daughter Board
- PCCproto 210-2 44/100 Pin Prototype Board
- PCCproto 210-3 100/144/176 Pin Prototype Board
- PCCproto 210-4 100/144/176 Pin Prototype Board
- PCCproto Connector Kit
  - Dual row 0.1" Male Header Assortment
  - Dual row 0.1" Female Header Assortment
- PCM16C02 Datasheet - July 1995
- PCM16C02 Application Note 975 - January 1995

- PCM16C02 Application Note 976 - January 1995
- PCM16C02 Application Note 980 - January 1995
- PCCproto 200 User's Manual
- PCM16C02 Client Source Code License Agreement
- PCCproto 200 Utility Diskette

### ***1.3 References***

PC Card Specification, February 1995 Release  
The PCMCIA Developer's Guide - Second Edition  
PCM16C02 Datasheet - July 1995  
PCM16C02 Application Note 975 - January 1995  
PCM16C02 Application Note 976 - January 1995  
PCM16C02 Application Note 980 - January 1995

## 2.0 Prototyping with the PCCproto 200

The PCCproto was designed to provide a flexible prototyping environment for PC Card designs. The PCCproto board is divided into several prototype zones. Certain zones accept plug-in daughter boards that support high pin count chips most often found in PC card designs. These high pin count devices are soldered directly onto the daughter board and plugged into the main prototype board. Included in the PCCproto kit are three daughter boards supporting a wide variety of chip types. Section 2.1 describes each zone and which daughter boards are compatible with that zone.

***Warning** - Familiarize yourself with the PCCproto's pin numbering and power supply grid before starting your prototype design. Failure to do so may result in damage to your prototype circuitry and/or your host system.*

### 2.1 PCCproto 200 Main Board

The PCCproto 200 consists of several prototype zones:

- PCMCIA host interface
- Interface Area
- Prototype Area 1
- Prototype Area 2
- Prototype Area 3 and 4
- Prototype Area 5 and 6
- I/O Connector Area
- Power Grid

**PCMCIA Host Interface** - The PCCproto connects to the PC Card host via a standard Type I interface. All 68 pins can be accessed via two 34 pin connectors at locations J1 and J2. Scope or logic analyzer probes may be connected to these areas.

**Interface Area** - Just past J1 and J2 is the interface area. This area contains the Vcc isolation and over current protection devices. Dual LEDs indicate 3.3V or 5V Vcc levels. A pushbutton switch can be configured to interrupt card detects (CD1 and CD2) to trick the host interface into thinking that the PC Card has been removed. This allows for hot insertion/removal testing without removing the card from the socket.

**Prototype Area 1** - Prototype area 1 is located at the center of the board. It is designed to accept the main PC Card interface chip (PCM16C02) which is mounted on a plug-in daughter board.

**Prototype Area 2** - Area 2 is designed to accept a PCCproto 210-x or 210-x daughter board. The 210-x and 210-x allow the user to mount the small TQFP packages typically found on ICs designed for PC Card applications.

**Prototype Area 3 and 4** - Designed to accept PCCproto 210-x daughter board. The PCCproto 210-x daughter board is designed to accept 44/64/100 pin TQFP or 44/100 pin PQFP packages.

**Prototype Area 5 and 6** - Designed for traditional devices on 0.1" centers.

**I/O Connector Area** - Three types of I/O connectors are supported in the I/O connector area. The area adjacent to Prototype area 5 support staggered 0.1" connectors. The connector pattern adjacent to Prototype area 6 supports SMT connectors with 0.031" or 0.050" spacing. Next to Prototype area 2 are standard 0.1" dual row locations for standard ribbon type connectors.

Figure 2.1-1 PCCproto Layout

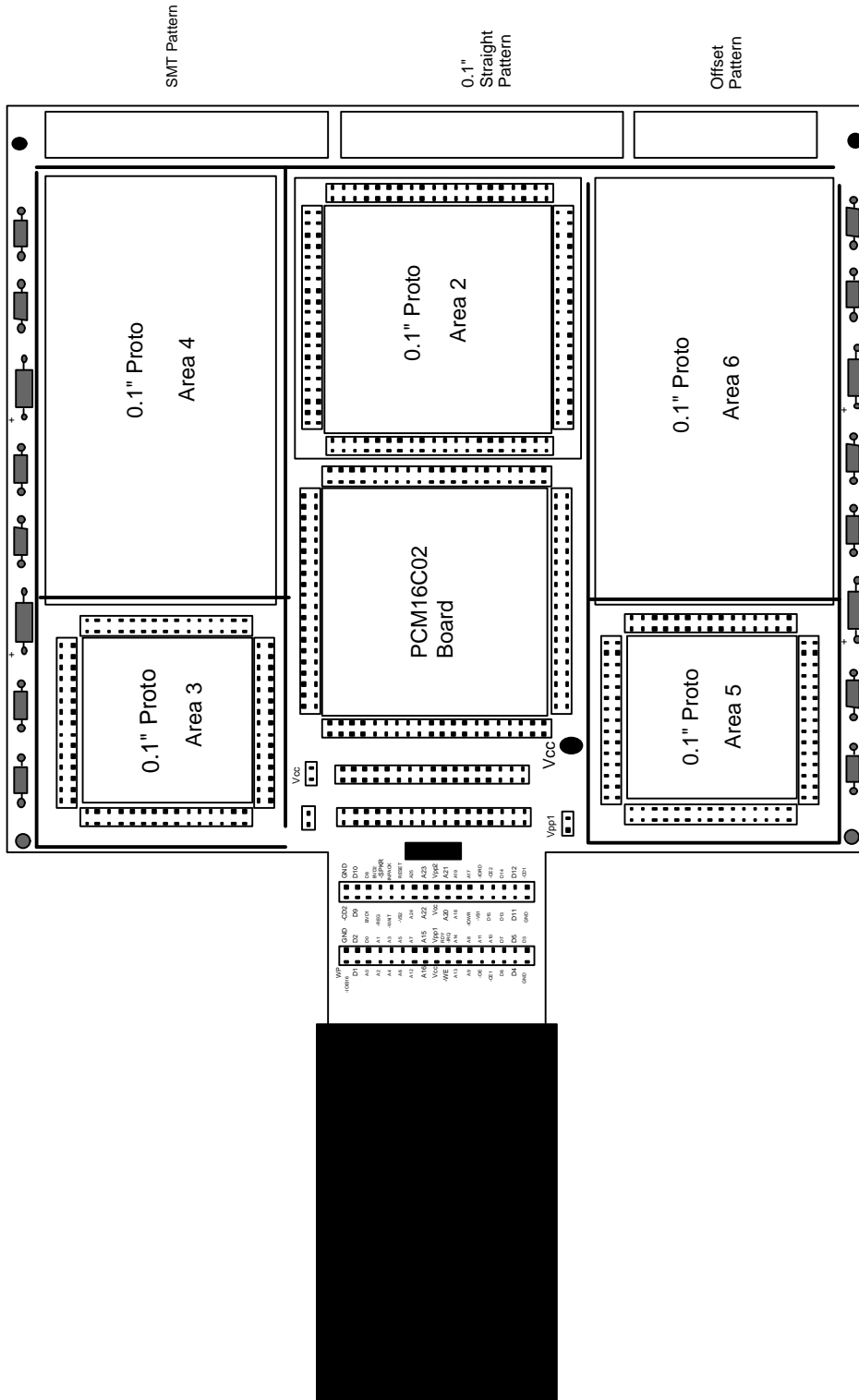

**Power Grid** - A clearly marked power grid allows access to the Vcc and Ground power planes. The power grid is marked with a silk-screen double line on both the component and circuits side of the board. Vcc is indicated by a diamond shaped pattern while Ground is indicated by a square pad. Bypass capacitors may be mounted between Vcc and ground anywhere in the grid.

### 2.1.1 Host Interface Area

The Host Interface area contains two 34 pin headers (J1 and J2) with the PC Card signals labeled. J1 and J2 can be used to connect a logic analyzer or scope probes. The two headers at J3 and J4 are used to connect the PC Card signals to the PCCproto 210-1 daughter board. The Vcc jumpers (JP5 and JP6) can be used to isolate the prototype's power from the host system.

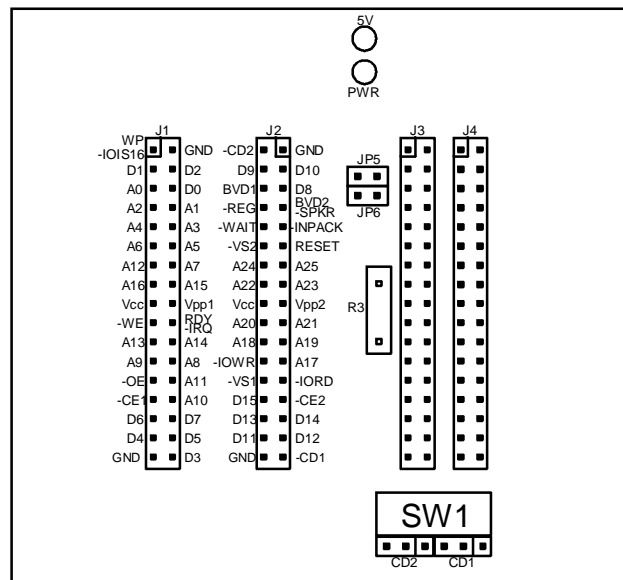

**Figure 2.1-2 Host Interface Area**

*Note:* Although J2 and J4 carry the same signals, the pin 1 location on the connectors is mirrored.

The PCCswap switch (SW1) can be configured to interrupt the card detect pins (-CD1 and -CD2). Jumpers CD1 and CD2 are described in section 3.4.

### 2.1.2 I/O connector Area

The I/O connector area supports three type of connectors. The SMT pattern routes 0.05" and 0.031" spaced pads to a standard dual row 0.1" header. A dual row 0.1" header accepts a wide variety of solder and wire-wrap headers.

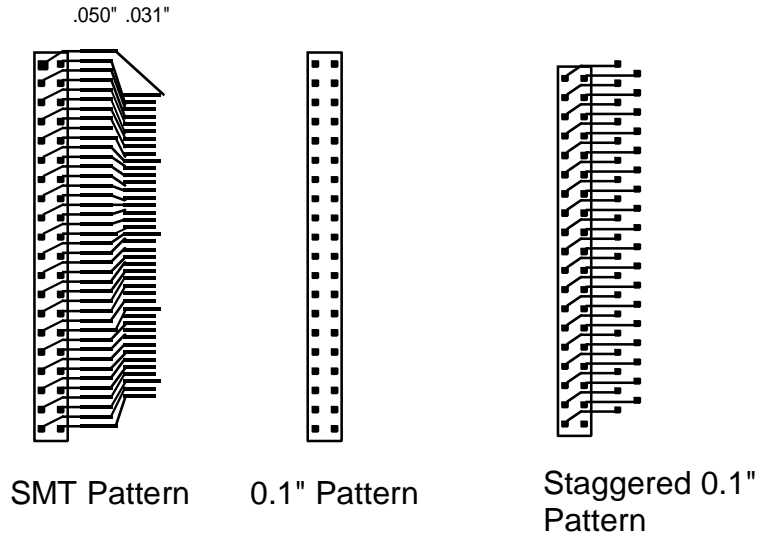

Figure 2.1-3 I/O Connector Area

### 2.1.3 Power Grid

The Power Grid allows access to the Vcc and ground planes. The grid is clearly marked with a double white lines. The Vcc plane is available through the square holes. The ground plane is accessed via the diamond shaped holes. Round holes within the grid are not tied to any plane.

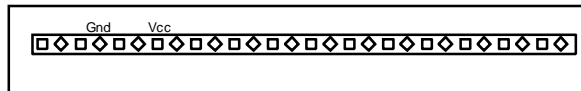
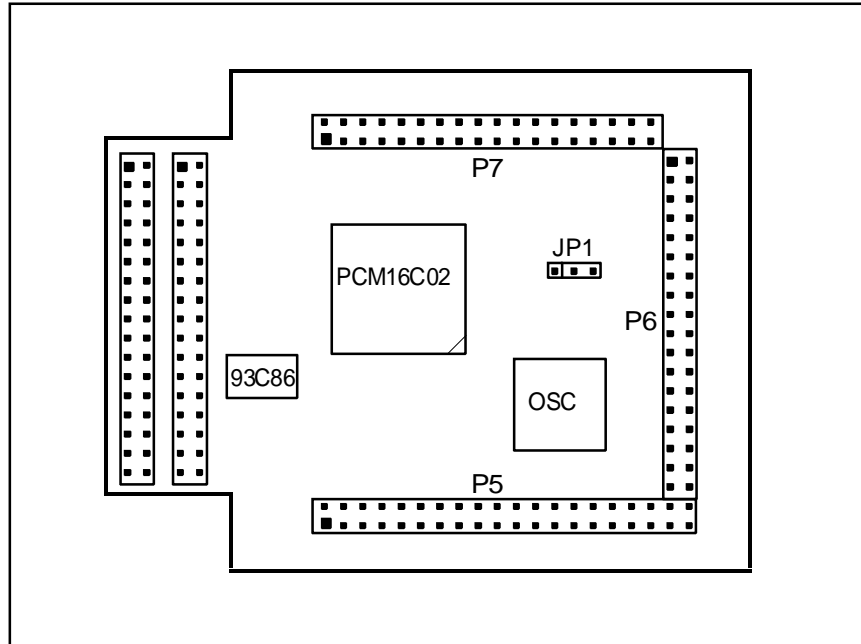

Figure 2.1-4 Power Grid

## 2.2 PCCproto 210-1 National Semiconductor PCM16C02

The PCM16C02 daughter board (PCCproto 210-1) contains the National Semiconductor PCM16C02 and associated circuitry. The 16C02 daughter board is designed to fit within prototype area 1. The PC Card interface signals and power are supplied on connectors J3 and J4 and routed directly to the PCM16C02 chip. The peripheral side of the PCM16C02 chip are accessible through the headers on prototype area 1.



**Figure 2.2-1 PCCproto 210-1 NSM 16C02 Daughter Board**

The PCM16C02 daughter board contains a 93C86A serial EEPROM used to store the Card Information Structure (CIS). The serial EEPROM is loaded on power-up into the PCM16C02's internal RAM memory.

The crystal oscillator at U3 supplied the clock required by the PCM16C02. If the designer wishes to use another clock source, it may be disabled by moving the jumper JP1 to pins 2-3.

JP1	1-2	2-3
	On-board clock	External Clock

**Table 2.2-1 PCCproto 210-1 Clock Select Jumper**

Information on interfacing and programming the PCM16C02 is included in National Semiconductor's application and data sheets included with the PCCproto 200 kit. Schematics for the PCCproto 210-1 are located in appendix A of this document.

***Note:** The PCM16C02 is left unconfigured on the PCCproto 200 board. In this unconfigured state it is possible to access internal registers and program the on-board EEPROM. It is up to the user to add their own peripheral circuitry to the prototype board. If used in the unconfigured state, the PCCproto may lockup the host system if the peripheral wait signals or interrupt lines are left unconnected..*

## 2.3 General Purpose Daughter Boards

The PCCproto 200 development kit includes three general purpose daughter boards. These boards can accept a wide variety of SMT packages typically used in PC Card applications.

Model	TQ64	TQ100	TQ144	TQ176	PQ44	PQ100	PQ144	PQ160
PCCproto 210-2		X	X	X				X
PCCproto 210-3	X	X			X	X		
PCCproto 210-4		X	X				X	

Table 2.3-1 PCCproto Daughter Boards

Since each different daughter board supports several packages, the pinouts of the board will differ depending on the package type. Appendix B lists the pin mapping for all the possible package type and daughter board combinations.

**Warning:** The pinout of the PCCproto 210-2, 210-3 and 210-4 differ depending on the type of IC package used. Carefully follow the pin mappings listed in appendix B or damage to your prototype or host may result.

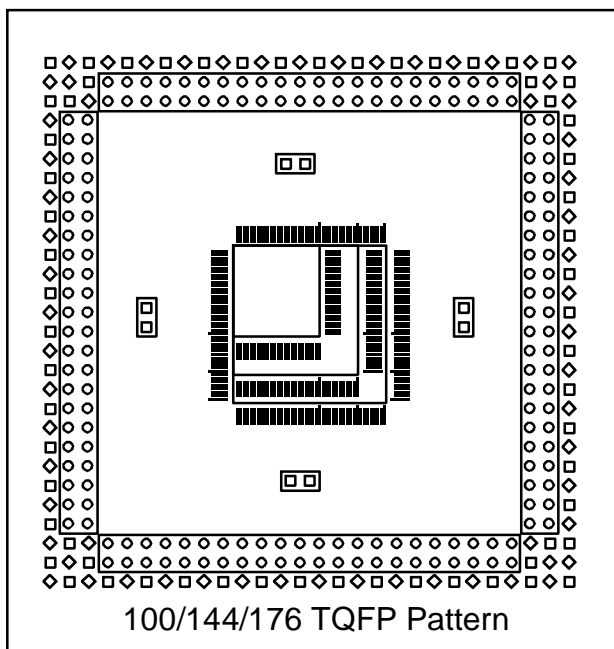

Figure 2.3-1 PCCproto 210-2 Pattern

The user may mount devices on either side of the PCCproto 210 boards depending on the pin count and lead pitch of the particular device. Once the devices are mounted, the female headers are mounted on the opposite side of the board.

### 2.3.1 Connecting Power to the PCCproto 210

All PCCproto 210 boards are of multilayer construction. A separate Vcc and Ground plane provide a low inductance source for the particular chip package. Access to the both the Vcc and Ground planes is provided at the edge of each daughter board. Square (VCC) and Diamond (GND) shaped holes identify the which power plane is attached. These pins may be directly connected to the appropriate pins on the particular chip.

Each daughter board contains four surface mount capacitor (1206 size) that are tied between Vcc and Ground that can be used to mount bypass capacitors.

### ***2.3.2 PCCproto 210-2***

The PCCproto 210-2 supports the larger package sizes. One side supports 100, 144 and 176 pin TQFP packages while the other side supports a 160 pin PQFP Package. The 176 pin pinout of the PCCproto 210-2 can be accepted in proto zones 1 and 2.

### ***2.3.3 PCCproto 210-4***

The PCCproto 210-4 supports 100 and 144 pin TQFP and 144 pin PQFP Package. The 144 pin pinout of the PCCproto 210-4 can be accepted in proto zones 1 and 2.

### ***2.3.4 PCCproto 210-3***

The PCCproto 210-3 supports 64 and 100 pin TQFP on one side and 44 and 100 pin PQFP Package on the other. The 104 pin pinout of the PCCproto 210-3 can be accepted in proto zones 3 and 4.

### 3.0 Prototyping Tips and Hints

The PCCproto 200 is designed to provide the designer with a flexible prototyping environment. However, as with any prototype the effects of long wires, poor power distribution and noise may impact your assembly. As with any prototype, proper planning prior to assembly will insure good results with the PCCproto. The following practices will reduce the effects of the prototype construction.

**Bypass and Bulk Capacitors** - Bypass and bulk capacitors may be placed between the Vcc and Ground planes on any of the power access points. Use low ESR (equivalent series resistance) X7R type ceramic capacitors of 0.1uF or greater. For bulk capacitance use tantalum capacitors. Be sure not to over-populate the tantalum capacitors. The in-rush current on card power-up may exceed the capability of the Vcc switch on your PC card host.

**Watch the power distribution** - Short paths from the PCCproto's power planes will reduce the effects of ground bounce and power supply noise.

**Watch undershoot and overshoot on I/O signals** - Under and over-shoot on PC card I/O signals can be a major problem with hardware prototypes. Many CMOS chips are very sensitive to negative undershoot and specify a maximum undershoot of between 0.5 and 0.7V. If your host or you prototype experience large amounts of undershoot, it may be wise to reduce it by using series resistors or some other terminating network.

**Be aware of the switched power environment of the PC Card interface** - The switched power environment of the PC Card interface can cause destructive latchup if.

**Be extremely careful using external power supplies.** - If for any reason an external power supply is used in your prototype insure that the power switched environment of the PC Card interface does not cause a latchup. The designer should consider a relay or some other protection device to prevent destructive latch-up.

### 3.1 Testing your PC Card implementation

There are several steps involved in debugging your PC Card design. The first step is to verify the functionality of the hardware. In order to reduce the number of variables in you hardware debug it is recommended that you disable Socket and Card Services. This can be accomplished by removing these entries in your CONFIG.SYS or AUTOEXEC.BAT.

The first step is to open I/O and/or memory windows to your prototype and enable power. To do this the user must be familiar with the architecture of the particular host socket controller. Accessing your host socket controller's internal registers is often a time consuming and frustrating experience. Most socket controller chip vendors have created socket controller debuggers. These utilities can usually be obtained without charge from your socket controller vendor. Once the windows have been opened, the user may enable the card's I/O or memory resources through attribute memory space. Once this have been accomplished the hardware can be debugged using any number of traditional debuggers including Microsoft's DEBUG.EXE.

*Note: In order to eliminate any possible interactions between your debugger and Socket/Card services disable Card and Socket Services by removing them from your CONFIG.SYS.*

Once the hardware has been debugged it is time to test your software client implementation with the hardware.

*Note: Before testing your hardware make sure that your PC Card software is installed properly and works with a variety of similar cards.*

Testing a client implementation involves inserting and removing a card to verify that the client interacts with Card Services to properly assign resources to your card. By configuring the PCCswap switch, the user may simulate insertion/removals without having to physically pull out the PC Card.

### 3.2 Measuring Current Consumption

The PCCproto Vcc power plane can be isolated from the host system's power via jumpers JP5 and JP6. When these two jumpers are removed an ammeter can be inserted in series to measure the prototype's power consumption.

**Warning:** Always insure that the slot power is removed before changing the positions of JP5 and JP6. A damaging latch-up condition may occur if CMOS devices are improperly power sequenced.

### 3.3 Current Protection Device

Located at R3 is a Raychem PolySwitch current protection device. This device is designed to protect the host's power supply from a Vcc to ground short on the PCCproto 200.

### 3.4 Using the PCCswap Switch

The PCCswap switch allow the user to momentarily disconnect the -CD1 and -CD2 signals from the PC card prototype. Headers CD1 and CD2 located near the PCCswap switch (SW1) enable operation of the switch.

Function	CD1 header	CD2 header
Enable PCCswap	1-2	1-2
Disable PCCswap	2-3	2-3

**Table 3.4-1 PCCswap Configuration Jumpers**

Once the PCCswap switch is enabled, a push of the switch will momentarily de-assert card detects. If Card Services is enabled, it should inform the client of the event and then remove power from the slot. When the switch is released card detects will be re-asserted. Card Services will re-power the slot and notify the client of the insertion event.

**Note:** In a properly configured system, pushing the PCCswap switch will cycle power to the host socket. Before using the PCCswap switch the user should determine if their prototype is immune from latchup problems (see section 3.0).

### 3.5 Signal Quality Problems

One of the most common signal quality problem is over and under shoot on the interface signals. The PC Card Specification dictates that the maximum Vih be no higher than Vcc+0.25 volts and the Vil be no lower than -0.3volts. Operation beyond these limits often times cause unreliable and unexpected errors with the PCCtest series of socket testers.

Why the problem? CMOS I/O pins are clamped against Vcc and Ground through protection diodes. When the input voltage exceeds Vcc, the Vcc protection diode will start conducting. The current induced through this clamping action may be quite high (depending on the magnitude over Vcc or below ground). This current may effect adjacent logic areas and cause unpredictable failures.

**Caution:** Do not ignore these failures. While many PC cards are tolerant of such over and undershoots, many are not.

## 4.0 Programming the EEPROM

The EEPROM on the PCCproto 210-1 board is used to store PCM16C02 configuration information and the Card Information Structure.

The steps involved in creating a Card Information Structure are beyond the scope of this document. Information on creating a CIS is available from a variety of sources including the PCMCIA Developer's Guide. Once the CIS has been created, it must be programmed in the EEPROM contained on the PCCproto 210-1 board. The PCCproto includes a utility PROTO.EXE that is designed to program a EEPROM connected to the PCM16C02 interface chip.

### 4.1 Programming the Attribute Memory

PROTO.EXE is a MSDOS application used to control the interface and program the EEPROM on the PCCproto 210-1. PROTO.EXE is a standalone program designed to run without Card and Socket Services. PROTO.EXE supports a wide variety of socket controller chips. Once the designer has created a binary image of the CIS it is ready to program into the PCM16C02's EEPROM.

*Note: PROTO.EXE requires that binary CIS image must be formatted on byte boundaries. There is no need to insert bytes between each CIS member.*

The PROTO.EXE is invoked through the following command line:

#### Syntax

```
PROTO -bxx -jx -ax
```

#### Switches

-ax PCIC Controller address select -a1 = 3E2-3E3H, -a2 = 3E3-3E4H,  
-a3 = 3E5-3E6H (default = 3E0-3E1H)

-bxx Select Socket controller xx = Socket controller  
b10 - Cirrus Logic CL-PD6710/6720  
b11 - Cirrus Logic CL-PD6722  
b12 - Cirrus Logic CL-PD6729/6730  
b20 - Vadem VG-365  
b21 - Vadem VG-465/468  
b22 - Vadem VG-469  
b30 - Intel 82365SL-DF  
b31 - Intel 82092AA PPEC  
b40 - Ricoh RF5C266/366  
b41 - Ricoh RF5C296/396  
b50 - VLSI 82C146  
b51 - VLSI 82C146A  
b60 - Texas Instruments PCI1050  
b61 - Texas Instruments PCI1030  
b62 - Texas Instruments PCI1130  
b70 - Omega Micro  
b71 - Omega Micro 82094 PCI - PCMCIA  
b90 - Databook  
b91 - Databook, ExCA Vpp Control

-jx Select alternate memory window. -j1 = C800:0 - CFFF:0, -j2 = E000:0 - E7FF:0

*Note: Switches can be entered in any order and must be separated by a space.*

## ***Appendix A***

### ***A. Schematics***

A.1 PCCproto 200 Schematic

A.2 PCCproto 210-1 Schematic

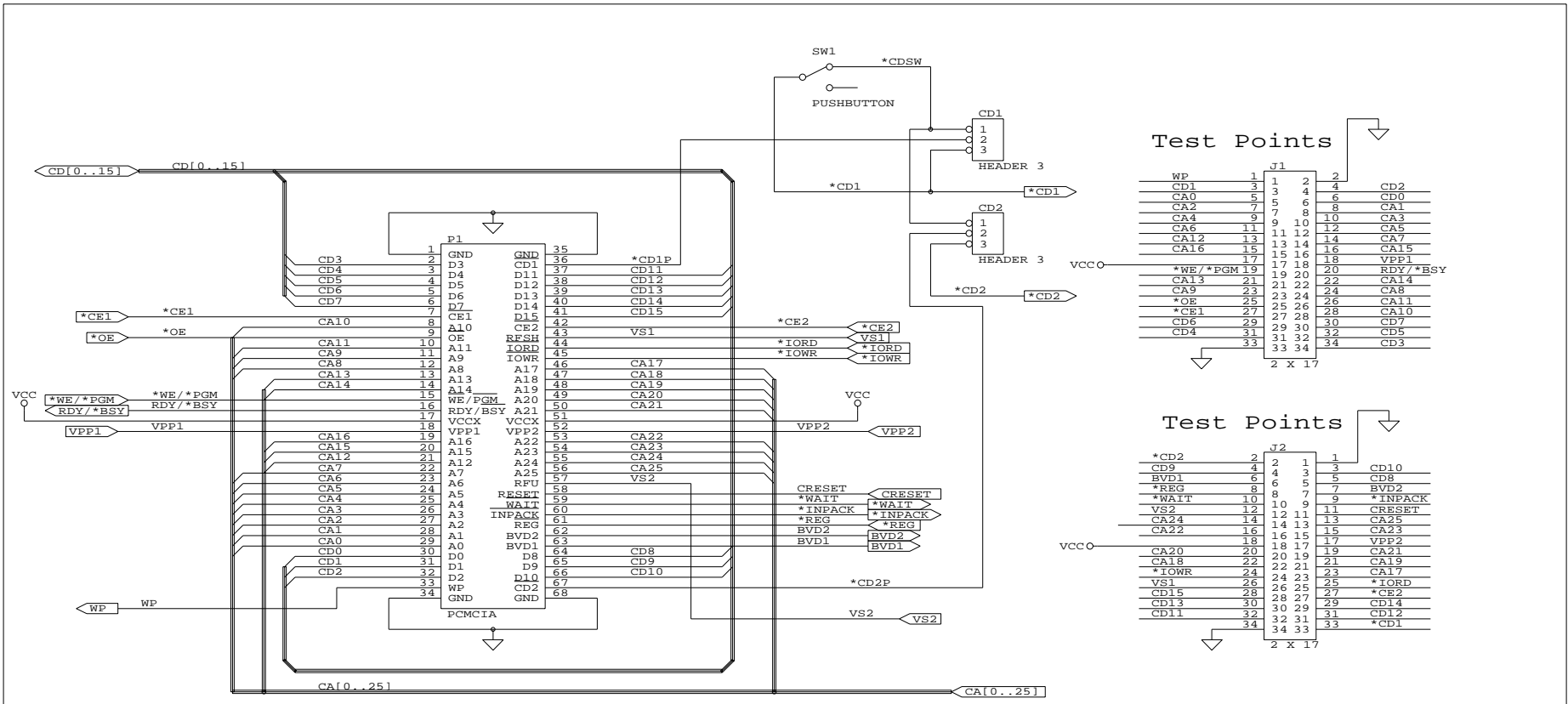

HOST SIDE CONNECTOR

Test Points

J1			
WP	1	2	CD2
CD1	3	4	CD0
CA0	5	6	CA1
CA2	7	8	CA3
CA4	9	10	CA5
CA6	11	12	CA7
CA12	13	14	CA15
CA16	15	16	VPP1
	17	18	RDY/*BSY
*WE/*PGM	19	20	CA14
CA13	21	22	CA8
*OE	23	24	CA11
*CE1	25	26	CA10
CD6	27	28	CD5
CD4	29	30	CD7
	31	32	CD3
	33	34	

2 X 17

Test Points

J2			
*CD2	2	1	CD10
CD9	4	3	CD8
BVD1	6	5	BVD2
*REG	8	7	*INPACK
*WAIT	10	9	CRESET
VS2	12	11	CA25
CA24	14	13	CA23
CA22	16	15	VPP2
	18	17	CA21
CA20	20	19	CA19
CA18	22	21	CA17
*IOWR	24	23	*IORD
VS1	26	25	*CE2
CD15	28	27	CD14
CD13	30	29	CD12
CD11	32	31	*CD1
	34	33	

2 X 17

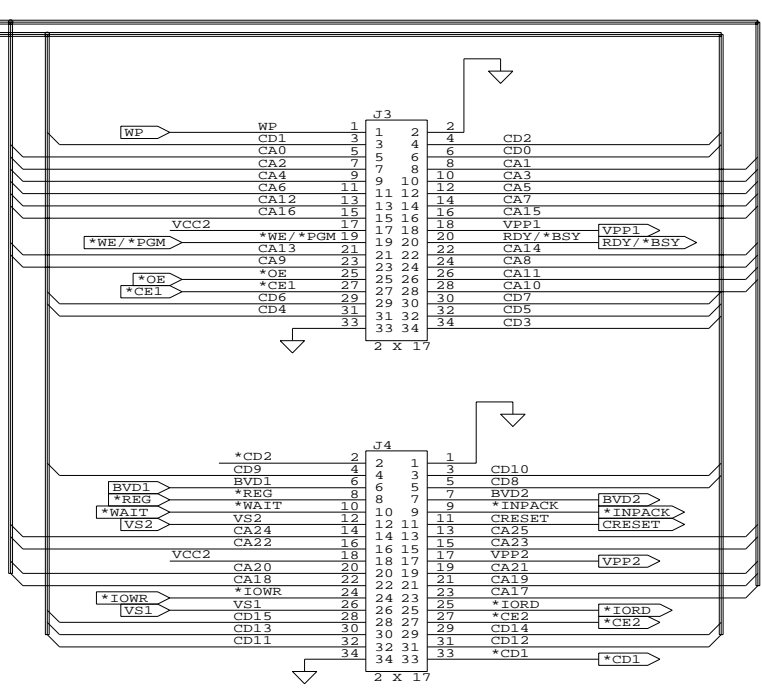
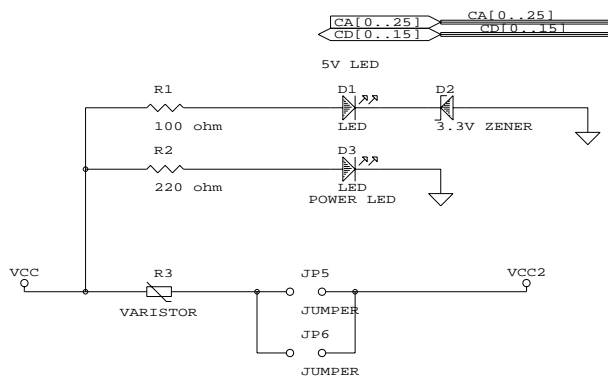

Sycard Technology		
Title		
PCCproto - Host Connector		
Size	Document Number	REV
B	140004	B
Date:	March 21, 1996	Sheet 2 of 2



## ***B. PCCproto Daughter Board Layouts***

- B.1 PCCproto 210-2 176/144/100 TQFP Side Layout
- B.2 PCCproto 210-2 176/144/100 TQFP Pinouts
- B.3 PCCproto 210-2 160 PQFP Side Layout
- B.4 PCCproto 210-2 160 PQFP Pinouts
- B.5 PCCproto 210-3 64/100 TQFP Side Layout
- B.6 PCCproto 210-3 64/100 TQFP Pinouts
- B.7 PCCproto 210-3 44/100 PQFP Side Layout
- B.8 PCCproto 210-3 44/100 PQFP Pinouts
- B.9 PCCproto 210-4 144/100 TQFP Side Layout
- B.10 PCCproto 210-4 144/100 TQFP Pinouts
- B.11 PCCproto 210-4 144 PQFP Side Layout
- B.12 PCCproto 210-4 144 PQFP Pinouts

### PCCproto 210-2 176/144/100 TQFP Side

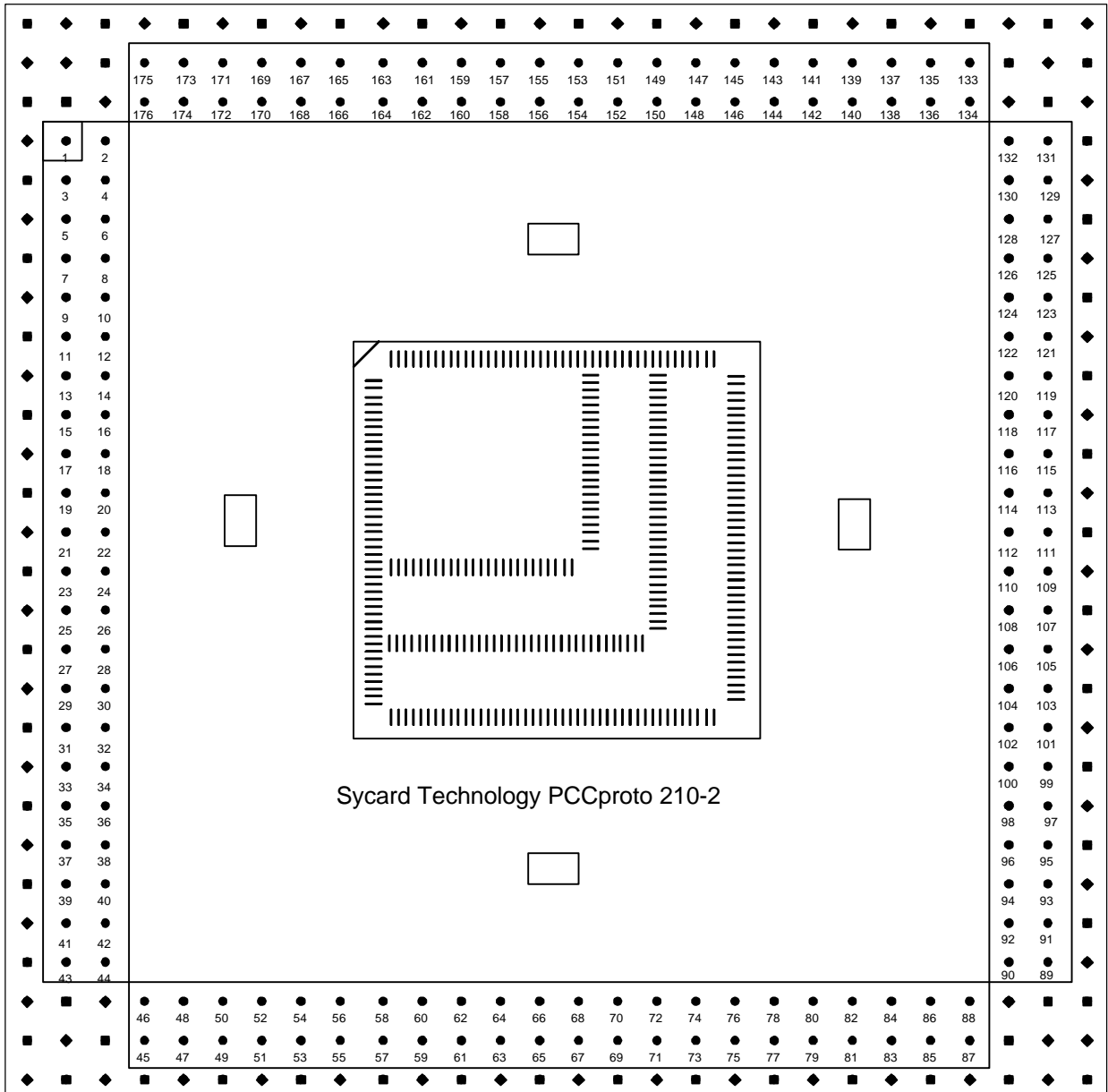

## PCCproto 210-2 100/144/176 TQFP Pin Mapping

Header	TQ100	TQ144	TQ176	Header	TQ100	TQ144	TQ176	Header	TQ100	TQ144	TQ176
1	1	1	1	61	42	53	61	120	63	96	120
2	2	2	2	62	43	54	62	121	64	97	121
3	3	3	3	63	44	55	63	122	65	98	122
4	4	4	4	64	45	56	64	123	66	99	123
5	5	5	5	65	46	57	65	124	67	100	124
6	6	6	6	66	47	58	66	125	68	101	125
7	7	7	7	67	48	59	67	126	69	102	126
8	8	8	8	68	49	60	68	127	70	103	127
9	9	9	9	69	50	61	69	128	71	104	128
10	10	10	10	70			70	129	72	105	129
11	11	11	11	71			71	130	73	106	130
12	12	12	12	72			72	131	74	107	131
13	13	13	13	73			73	132	75	108	132
14	14	14	14	74			74	133			133
15	15	15	15	75			75	134			134
16	16	16	16	76			76	135			135
17	17	17	17	77			77	136			136
18	18	18	18	78			78	137			137
19	19	19	19	79			79	138			138
20	20	20	20	80			80	139			139
21	21	21	21	81			81	140			140
22	22	22	22	82			82	141		109	141
23	23	23	23	83			83	142		110	142
24	24	24	24	84			84	143		111	143
25	25	25	25	85			85	144		112	144
26		26	26	86			86	145		113	145
27		27	27	87			87	146		114	146
28		28	28	88			88	147		115	147
29		29	29	89			89	148		116	148
30		30	30	90			90	149		117	149
31		31	31	91			91	150		118	150
32		32	32	92			92	151		119	151
33		33	33	93			93	152	76	120	152
34		34	34	94			94	153	77	121	153
35		35	35	95			95	154	78	122	154
36		36	36	96			96	155	79	123	155
37			37	97			97	156	80	124	156
38			38	98			98	157	81	125	157
39			39	99			99	158	82	126	158
40			40	100			100	159	83	127	159
41			41	101			101	160	84	128	160
42			42	102			102	161	85	129	161
43			43	103			103	162	86	130	162
44			44	104			104	163	87	131	163
45	26	37	45	105			105	164	88	132	164
46	27	38	46	106			106	165	89	133	165
47	28	39	47	107			107	166	90	134	166
48	29	40	48	108	51	84	108	167	91	135	167
49	30	41	49	109	52	85	109	168	92	136	168
50	31	42	50	110	53	86	110	169	93	137	169

## PCCproto 210-2 100/144/176 TQFP Pin Mapping

Header	TQ100	TQ144	TQ176	Header	TQ100	TQ144	TQ176	Header	TQ100	TQ144	TQ176
v51	32	43	51	111	54	87	111	170	94	138	170
52	33	44	52	112	55	88	112	171	95	139	171
53	34	45	53	113	56	89	113	172	96	140	172
54	35	46	54	114	57	90	114	173	97	141	173
55	36	47	55	115	58	91	115	174	98	142	174
56	37	48	56	116	59	92	116	175	99	143	175
57	38	49	57	117	60	93	117	176	100	144	176
58	39	50	58	118	61	94	118				
59	40	51	59	119	62	95	119				
60	41	52	60	120	63	96	120				

### PCCproto 210-2 160 PQFP Side

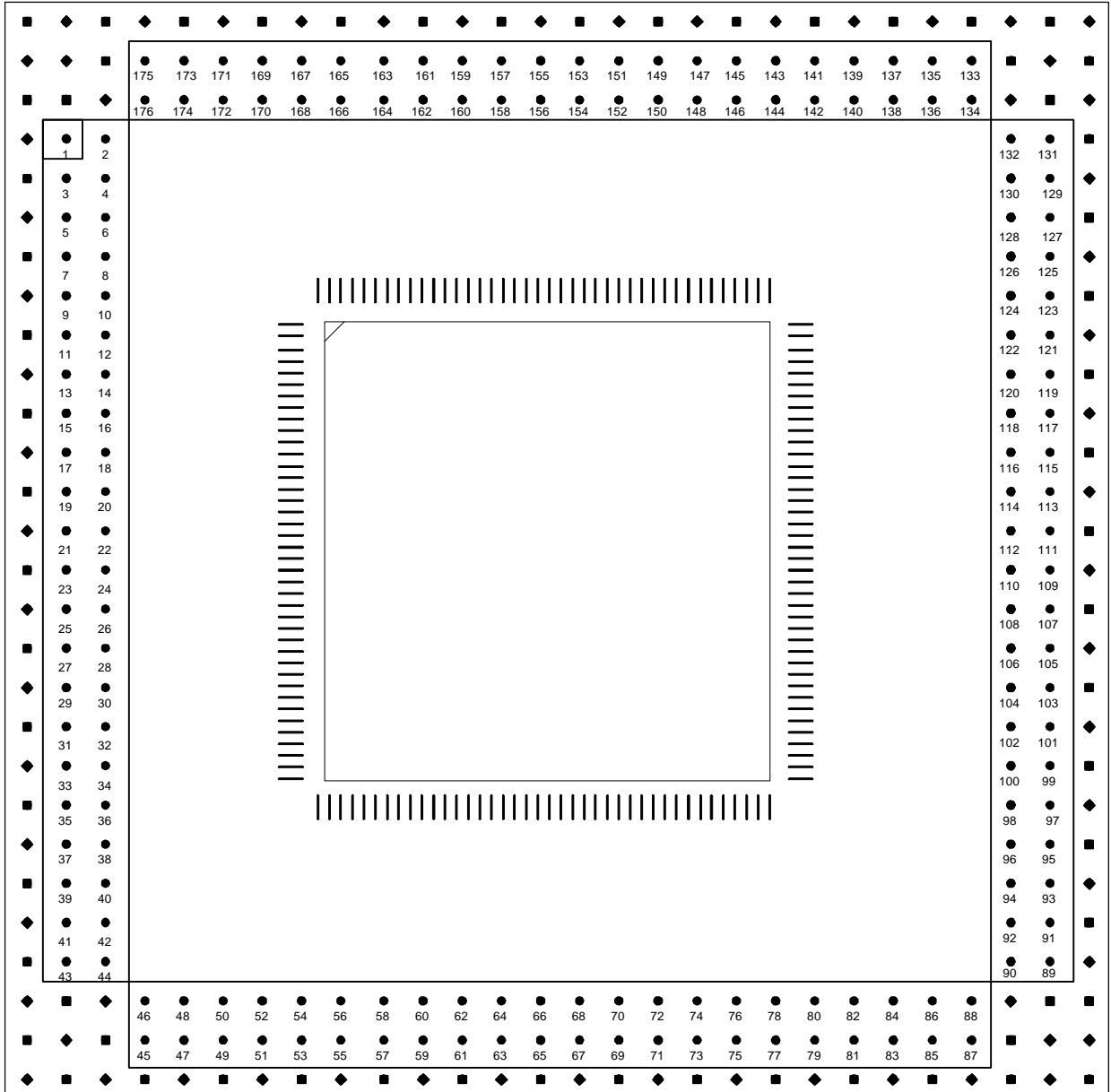

## PCCproto 210-2 160 pin PQFP pin mapping

Header	PQ160	Header	PQ160	Header	PQ160
1		61	55	121	111
2		62	56	122	112
3	1	63	57	123	113
4	2	64	58	124	114
5	3	65	59	125	115
6	4	66	60	126	116
7	5	67	61	127	117
8	6	68	62	128	118
9	7	69	63	129	119
10	8	70	64	130	120
11	9	71	65	131	
12	10	72	66	132	
13	11	73	67	133	
14	12	74	68	134	
15	13	75	69	135	121
16	14	76	70	136	122
17	15	77	71	137	123
18	16	78	72	138	124
19	17	79	73	139	125
20	18	80	74	140	126
21	19	81	75	141	127
22	20	82	76	142	128
23	21	83	77	143	129
24	22	84	78	144	130
25	23	85	79	145	131
26	24	86	80	146	132
27	25	87		147	133
28	26	88		148	134
29	27	89		149	135
30	28	90		150	136
31	29	91	81	151	137
32	30	92	82	152	138
33	31	93	83	153	139
34	32	94	84	154	140
35	33	95	85	155	141
36	34	96	86	156	142
37	35	97	87	157	143
38	36	98	88	158	144
39	37	99	89	159	145
40	38	100	90	160	146
41	39	101	91	161	147
42	40	102	92	162	148
43		103	93	163	149
44		104	94	164	150
45		105	95	165	151
46		106	96	166	152
47	41	107	97	167	153
48	42	108	98	168	154

## PCCproto 210-2 160 pin PQFP pin mapping

Header	PQ160		Header	PQ160		Header	PQ160	
49	43		109	99		169	155	
50	44		110	100		170	156	
51	45		111	101		171	157	
52	46		112	102		172	158	
53	47		113	103		173	159	
54	48		114	104		174	160	
55	49		115	105		175		
56	50		116	106		176		
57	51		117	107				
58	52		118	108				
59	53		119	109				
60	54		120	110				



## PCCproto 210-3 64/100 TQFP Pin Mapping

Header	TQ64	TQ100		Header	TQ64	TQ100
1	1	1		53		51
2	2	2		54		52
3	3	3		55		53
4	4	4		56		54
5	5	5		57		55
6	6	6		58		56
7	7	7		59		57
8	8	8		60		58
9	9	9		61		59
10	10	10		62	33	60
11	11	11		63	34	61
12	12	12		64	35	62
13	13	13		65	36	63
14	14	14		66	37	64
15	15	15		67	38	65
16	16	16		68	39	66
17		17		69	40	67
18		18		70	41	68
19		19		71	42	69
20		20		72	43	70
21		21		73	44	71
22		22		74	45	72
23		23		75	46	73
24		24		76	47	74
25		25		77	48	75
26				78		
27	18	27		79		77
28	17	26		80		76
29	20	29		81		79
30	19	28		82		78
31	22	31		83		81
32	21	30		84		80
33	24	33		85		83
34	23	32		86		82
35	26	35		87	49	85
36	25	34		88		84
37	28	37		89	51	87
38	27	36		90	50	86
39	30	39		91	53	89
40	29	38		92	52	88
41	32	41		93	55	91
42	31	40		94	54	90
43		43		95	57	93
44		42		96	56	92
45		45		97	59	95
46		44		98	58	94
47		47		99	61	97
48		46		100	60	96

## PCCproto 210-3 64/100 TQFP Pin Mapping

<b>Header</b>	<b>TQ64</b>	<b>TQ100</b>		<b>Header</b>	<b>TQ64</b>	<b>TQ100</b>
49		49		101	63	99
50		48		102	62	98
51				103		
52		50		104	64	104

### PCCproto 210-3 44/100 PQFP Side

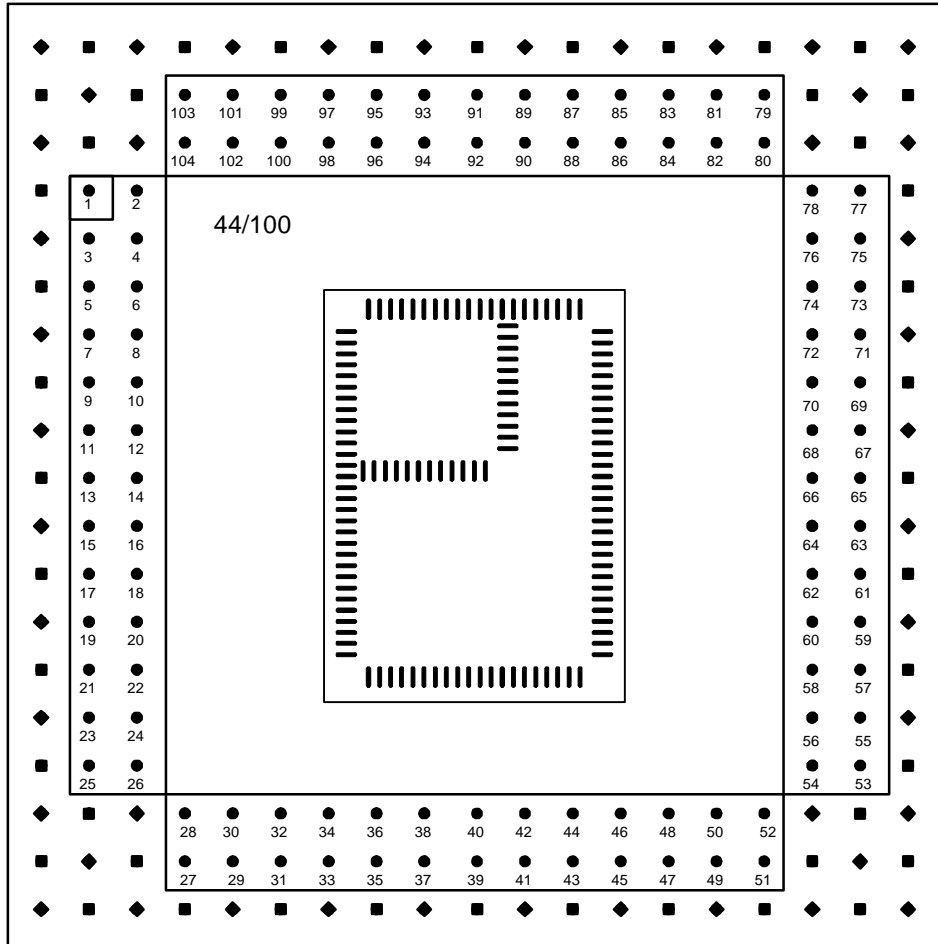

**PCCproto 210-3 44/100 side**

Header	PQ44	PQ100		Header	PQ44	PQ100
1	1	1		53		51
2	2	2		54		52
3	3	3		55		53
4	4	4		56		54
5	5	5		57		55
6	6	6		58		56
7	7	7		59		57
8	8	8		60		58
9	9	9		61		59
10	10	10		62		60
11	11	11		63		61
12		12		64		62
13		13		65		63
14		14		66		64
15		15		67		65
16		16		68		66
17		17		69		67
18		18		70		68
19		19		71		69
20		20		72	23	70
21		21		73	24	71
22		22		74	25	72
23		23		75	26	73
24		24		76	27	74
25		25		77	28	75
26				78		
27		27		79		77
28		26		80		76
29		29		81		79
30		28		82		78
31	12	31		83		81
32	13	30		84		80
33	14	33		85		83
34	15	32		86		82
35	16	35		87		85
36	17	34		88		84
37	18	37		89		87
38	19	36		90		86
39	20	39		91		89
40	21	38		92		88
41	22	41		93	35	91
42		40		94	34	90
43		43		95	37	93
44		42		96	36	92
45		45		97	39	95
46		44		98	38	94
47		47		99	41	97
48		46		100	40	96

**PCCproto 210-3 44/100 side**

<b>Header</b>	<b>PQ44</b>	<b>PQ100</b>		<b>Header</b>	<b>PQ44</b>	<b>PQ100</b>
49		49		101	43	99
50		48		102	42	98
51				103		
52		50		104	44	100

### PCCproto 210-4 100/144 TQFP Side

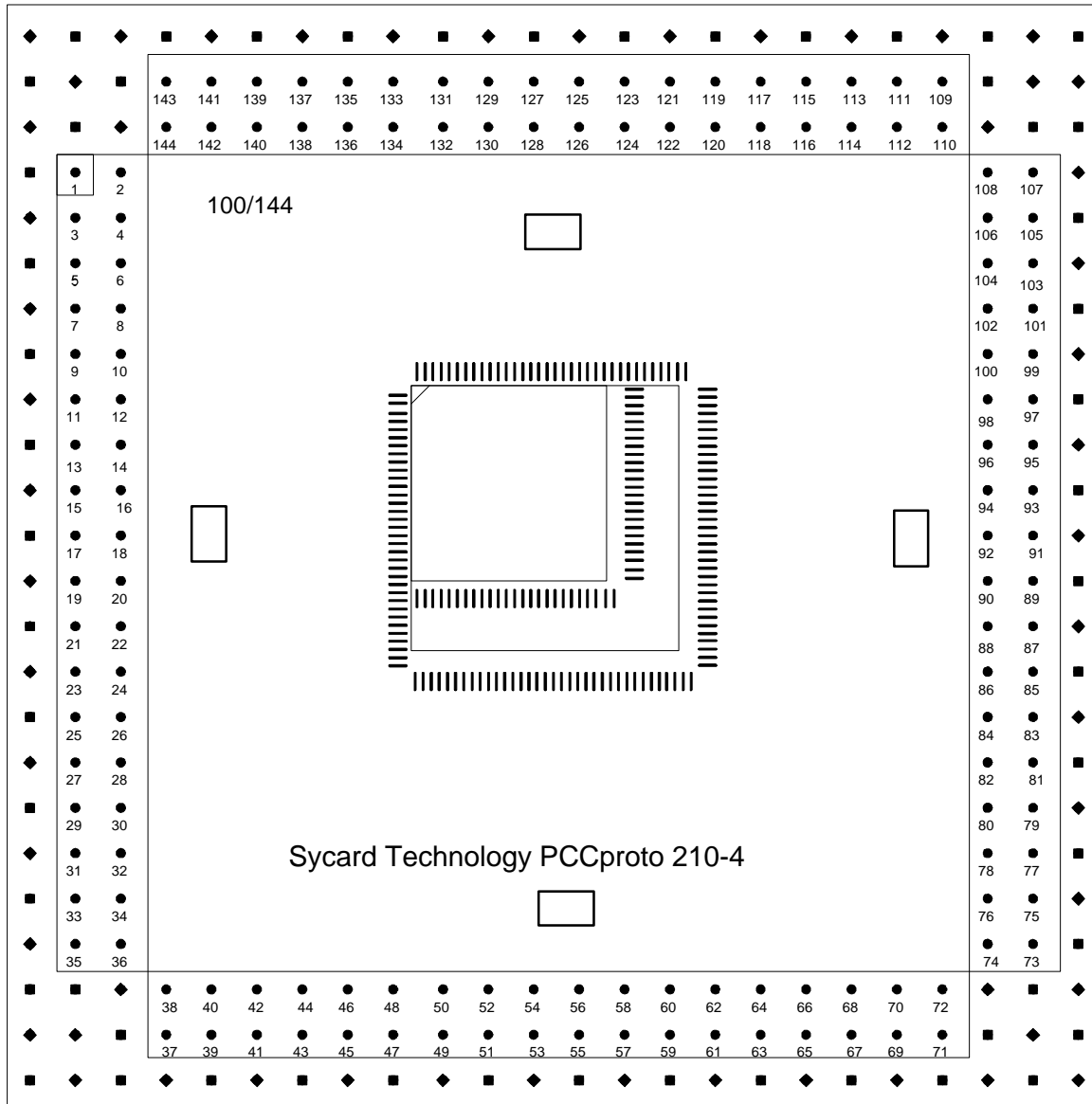

<b>PCCproto 210-4 100/144 pin TQFP pin mapping</b>										
Header	TQ100	TQ144		Header	TQ100	TQ144		Header	TQ100	TQ144
1	1	1		61	50	61		121	77	121
2	2	2		62		62		122	78	122
3	3	3		63		63		123	79	123
4	4	4		64		64		124	80	124
5	5	5		65		65		125	81	125
6	6	6		66		66		126	82	126
7	7	7		67		67		127	83	127
8	8	8		68		68		128	84	128
9	9	9		69		69		129	85	129
10	10	10		70		70		130	86	130
11	11	11		71		71		131	87	131
12	12	12		72		72		132	88	132
13	13	13		73		73		133	89	133
14	14	14		74		74		134	90	134
15	15	15		75		75		135	91	135
16	16	16		76		76		136	92	136
17	17	17		77		77		137	93	137
18	18	18		78		78		138	94	138
19	19	19		79		79		139	95	139
20	20	20		80		80		140	96	140
21	21	21		81		81		141	97	141
22	22	22		82		82		142	98	142
23	23	23		83		83		143	99	143
24	24	24		84	51	84		144	100	144
25	25	25		85	52	85				
26		26		86	53	86				
27		27		87	54	87				
28		28		88	55	88				
29		29		89	56	89				
30		30		90	57	90				
31		31		91	58	91				
32		32		92	59	92				
33		33		93	60	93				
34		34		94	61	94				
35		35		95	62	95				
36		36		96	63	96				
37	26	37		97	64	97				
38	27	38		98	65	98				
39	28	39		99	66	99				
40	29	40		100	67	100				
41	30	41		101	68	101				
42	31	42		102	69	102				
43	32	43		103	70	103				
44	33	44		104	71	104				
45	34	45		105	72	105				
46	35	46		106	73	106				
47	36	47		107	74	107				

<b>PCCproto 210-4 100/144 pin TQFP pin mapping</b>										
<b>Header</b>	<b>TQ100</b>	<b>TQ144</b>		<b>Header</b>	<b>TQ100</b>	<b>TQ144</b>		<b>Header</b>	<b>TQ100</b>	<b>TQ144</b>
48	37	48		108	75	108				
49	38	49		109		109				
50	39	50		110		110				
51	40	51		111		111				
52	41	52		112		112				
53	42	53		113		113				
54	43	54		114		114				
55	44	55		115		115				
56	45	56		116		116				
57	46	57		117		117				
58	47	58		118		118				
59	48	59		119		119				
60	49	60		120	76	120				

### PCCproto 210-4 144 PQFP Side

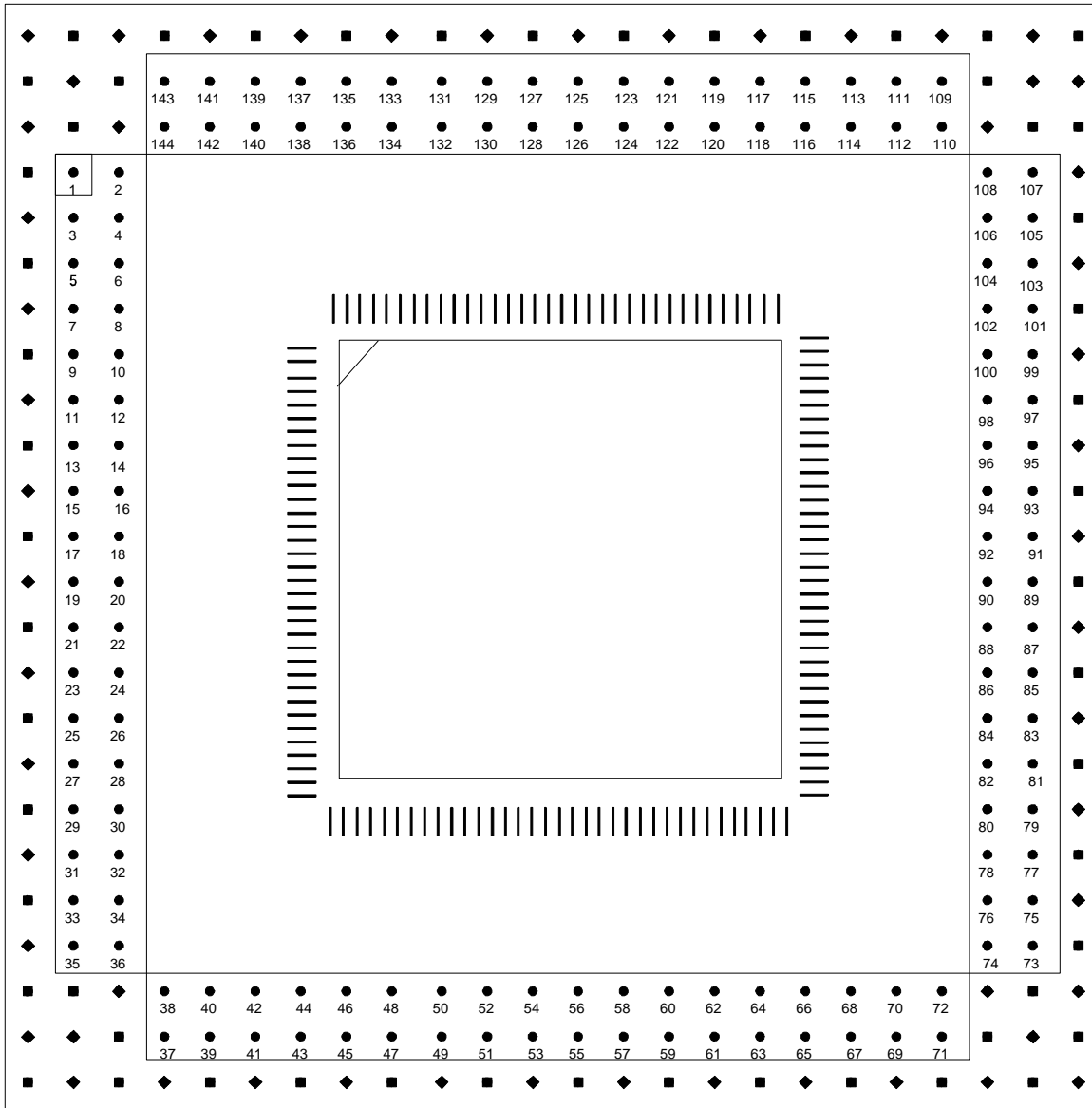

## PCCproto 210-4 144 pin PQFP pin mapping

Header	PQ144		Header	PQ144		Header	PQ144
1	1		61	61		121	121
2	2		62	62		122	122
3	3		63	63		123	123
4	4		64	64		124	124
5	5		65	65		125	125
6	6		66	66		126	126
7	7		67	67		127	127
8	8		68	68		128	128
9	9		69	69		129	129
10	10		70	70		130	130
11	11		71	71		131	131
12	12		72	72		132	132
13	13		73	73		133	133
14	14		74	74		134	134
15	15		75	75		135	135
16	16		76	76		136	136
17	17		77	77		137	137
18	18		78	78		138	138
19	19		79	79		139	139
20	20		80	80		140	140
21	21		81	81		141	141
22	22		82	82		142	142
23	23		83	83		143	143
24	24		84	84		144	144
25	25		85	85			
26	26		86	86			
27	27		87	87			
28	28		88	88			
29	29		89	89			
30	30		90	90			
31	31		91	91			
32	32		92	92			
33	33		93	93			
34	34		94	94			
35	35		95	95			
36	36		96	96			
37	37		97	97			
38	38		98	98			
39	39		99	99			
40	40		100	100			
41	41		101	101			
42	42		102	102			
43	43		103	103			
44	44		104	104			
45	45		105	105			
46	46		106	106			
47	47		107	107			
48	48		108	108			
49	49		109	109			

## PCCproto 210-4 144 pin PQFP pin mapping

<b>Header</b>	<b>PQ144</b>		<b>Header</b>	<b>PQ144</b>		<b>Header</b>	<b>PQ144</b>
50	50		110	110			
51	51		111	111			
52	52		112	112			
53	53		113	113			
54	54		114	114			
55	55		115	115			
56	56		116	116			
57	57		117	117			
58	58		118	118			
59	59		119	119			
60	60		120	120			

## ***C. Ordering Additional PCCproto Modules***

Additional PCCproto daughter boards may be ordered directly from Sycard Technology. The following boards are available:

<b>Model Number</b>	<b>Supports</b>
PCCproto 210-2	44/64/100 TQFP 44/100 PQFP
PCCproto 210-3	64/100/144 TQFP 144 PQFP
PCCproto 210-4	100/144/176 TQFP 160 PQFP

## ***D. The PCM16C02 Utility Diskette***

The PCM16C02 utility diskette includes several files

1. Orcad schematics PCCproto 210-1
2. Orcad schematics PCCproto 200 Main Board
3. Orcad Library element for PCM16C02

## Appendix E - PCMCIA Interface

### PC Card Pinout - Memory Mode

Pin	Name	Description	Pin	Name	Description
1	GND	Ground	35	GND	Ground
2	D3	Data Bit 3	36	CD1#	Card Detect 1
3	D4	Data Bit 4	37	D11	Data Bit 11
4	D5	Data Bit 5	38	D12	Data Bit 12
5	D6	Data Bit 6	39	D13	Data Bit 13
6	D7	Data Bit 7	40	D14	Data Bit 14
7	CE1#	Card Enable 1	41	D15	Data Bit 15
8	A10	Address Bit 10	42	CE2#	Card Enable 2
9	OE#	Output Enable	43	VS1#	Voltage Sense 1
10	A11	Address Bit 11	44	RFU	Reserved
11	A9	Address Bit 9	45	RFU	Reserved
12	A8	Address Bit 8	46	A17	Address Bit 17
13	A13	Address Bit 13	47	A18	Address Bit 18
14	A14	Address Bit 14	48	A19	Address Bit 19
15	WE#	Write Enable	49	A20	Address Bit 20
16	READY	Ready/Busy	50	A21	Address Bit 21
17	VCC	Card Power	51	VCC	Card Power
18	VPP1	Programming Supply Voltage 1	52	VPP2	Programming Supply Voltage 2
19	A16	Address Bit 16	53	A22	Address Bit 22
20	A15	Address Bit 15	54	A23	Address Bit 23
21	A12	Address Bit 12	55	A24	Address Bit 24
22	A7	Address Bit 7	56	A25	Address Bit 25
23	A6	Address Bit 6	57	VS2#	Voltage Sense 2
24	A5	Address Bit 5	58	RESET	Card Reset
25	A4	Address Bit 4	59	WAIT#	Extend Bus Cycle
26	A3	Address Bit 3	60	RFU	Reserved
27	A2	Address Bit 2	61	REG#	Register Select
28	A1	Address Bit 1	62	BVD2	Battery Voltage Detect 2
29	A0	Address Bit 0	63	BVD1	Battery Voltage Detect 1
30	D0	Data Bit 0	64	D8	Data Bit 8
31	D1	Data Bit 1	65	D9	Data Bit 9
32	D2	Data Bit 2	66	D10	Data Bit 10
33	WP	Write Protect	67	CD2#	Card Detect 2
34	GND	Ground	68	GND	Ground

## PC Card Pinout - I/O Mode

Pin	Name	Description	Pin	Name	Description
1	GND	Ground	35	GND	Ground
2	D3	Data Bit 3	36	CD1#	Card Detect 1
3	D4	Data Bit 4	37	D11	Data Bit 11
4	D5	Data Bit 5	38	D12	Data Bit 12
5	D6	Data Bit 6	39	D13	Data Bit 13
6	D7	Data Bit 7	40	D14	Data Bit 14
7	CE1#	Card Enable 1	41	D15	Data Bit 15
8	A10	Address Bit 10	42	CE2#	Card Enable 2
9	OE#	Output Enable	43	VS1#	Voltage Sense 1
10	A11	Address Bit 11	44	IORD#	I/O Read Strobe
11	A9	Address Bit 9	45	IOWR#	I/O Write Strobe
12	A8	Address Bit 8	46	A17	Address Bit 17
13	A13	Address Bit 13	47	A18	Address Bit 18
14	A14	Address Bit 14	48	A19	Address Bit 19
15	WE#	Write Enable	49	A20	Address Bit 20
16	IREQ#	Interrupt Request	50	A21	Address Bit 21
17	VCC	Card Power	51	VCC	Card Power
18	VPP1	Programming Supply Voltage 1	52	VPP2	Programming Supply Voltage 2
19	A16	Address Bit 16	53	A22	Address Bit 22
20	A15	Address Bit 15	54	A23	Address Bit 23
21	A12	Address Bit 12	55	A24	Address Bit 24
22	A7	Address Bit 7	56	A25	Address Bit 25
23	A6	Address Bit 6	57	VS2#	Voltage Sense 2
24	A5	Address Bit 5	58	RESET	Card Reset
25	A4	Address Bit 4	59	WAIT#	Extend Bus Cycle
26	A3	Address Bit 3	60	INPACK#	Input Port Acknowledge
27	A2	Address Bit 2	61	REG#	Register and I/O select enable
28	A1	Address Bit 1	62	SPKR#	Digital Audio Waveform
29	A0	Address Bit 0	63	STSCHG#	Card Status Changed
30	D0	Data Bit 0	64	D8	Data Bit 8
31	D1	Data Bit 1	65	D9	Data Bit 9
32	D2	Data Bit 2	66	D10	Data Bit 10
33	IOIS16#	IO Port is 16 bits	67	CD2#	Card Detect 2
34	GND	Ground	68	GND	Ground

# Appendix F - Connector Drawings

