



SYCARD
TECHNOLOGY

PCCtest 170 User's Manual

***M200032-02
December 2002***

Preliminary

***Sycard Technology
1180-F Miraloma Way
Sunnyvale, CA 94085
(408) 749-0130
(408) 749-1323 FAX
<http://www.sycard.com>***

1.0 Introduction

The PCCtest 170 PC Card socket tester is designed to provide manufacturers of PC Card based hosts a quick method of testing and verifying the operation of PC Card sockets. The PCCtest 170 socket tester is a 16-bit PC Card. It is designed to test the sockets 16-bit interface.

The PCCtest unit is a Type II PC Card that plugs into a standard Type II or III socket. The test unit is designed for both automated GO/NO-GO testing and component level debug. Test software resides on both the host PC and PCCtest unit. Simple command line invocation allows tests to be embedded into batch test files.

The PCCtest contains an on-board A/D to provide accurate measurement of VCC and VPP voltages. A digital audio test provides a standard 1KHz tone to test the audio function when the PC card is configured for I/O mode.

PCCtest is compatible with any Type II or III socket designed to support the PCMCIA Release 2.1 or higher standard. Software included with the PCCtest unit supports a wide variety of socket controllers based on the Intel 82365SL. The latest release of the software supports a wide variety of PCI based socket controllers including CardBus controllers. For other socket controller architectures, Sycard Technology can provide technical documentation describing how to create custom test programs for the PCCtest series of socket controllers.

1.2 Compatibility

PCCtest has been designed to be compatible with a wide variety of host socket controllers. Host test software is compatible with most PC compatible machines. The current software supports the following socket controllers:

- All Intel 16-bit Socket Controllers
- All Vadem Single and dual slot socket controllers
- All Cirrus Logic/Basis/Intel 16b-ti Single/Dual socket controller
- Cirrus Logic/Basis/Intel CL-PD6832/6833/6834 CardBus Controller **
- All Ricoh 16-bit PC Card socket controller
- Ricoh RF5C466 Dual socket CardBus - PCI Interface**
- Ricoh RF5C465/475 Single socket CardBus - PCI Interface **
- Ricoh RF5C476/478 Dual socket CardBus - PCI Interface **
- VLSI Technology 82C146/82C146A socket controllers
- Omega Micro 82C365G/82C722G/92C094 Dual socket controllers
- Omega/Trident 82C196 Dual socket CardBus controller - PCI Interface
- TI PCI1050/1031 – PC Card-16 PCI Interface
- All TI CardBus controllers **
- All O2 Micro CardBus controller **
- All ENE CardBus controllers **
- Databook DB86082A Dual socket controller
- Other socket controllers fully compatible with the Intel 82365SL

**The PCCtest 170 support testing of the 16-bit portion of the CardBus controller only

1.3 Specifications

Electrical

Supply Voltage	5V \pm 10% or 3.3V \pm 0.3V
Supply Current	90mA max

Physical

Height	5.0mm
--------	-------

Length	85.6mm
Width	54mm

Environmental

Temperature	0 - 50 degrees C
Humidity	0 - 95 % Non condensing

Reliability

Connector Life Rated at 10,000 insertion/removal cycles (PCMCIA specification). Actual life is estimated to be 20,000+ cycles.

1.4 Packing List

The PCCtest package includes the following:

- PCCtest 170 Test Unit
- PCCtest Test Software Diskette
- PCCtest User's Manual

1.5 Related Documentation

PCMCIA PC Card Specification, Release 2.1
 PCMCIA PC Card Specification, Release 5.0
 The PCMCIA Developer's Guide, 3rd Edition - Sycard Technology
 Exchangeable Card Architecture (ExCA) release 1.5
 Vadem VG-365, 465, 468, 469 Data Manual
 Cirrus Logic CL-PD6710/PD672X Data Sheet
 Cirrus Logic CL-PD6729 Data Sheet
 Cirrus Logic CL-PD6730 Data Sheet
 Cirrus Logic CL-PD6832 Data Sheet
 VLSI Technology 82C146 Functional Specification
 VLSI Technology 82C146A Functional Specification
 Intel 82365SL Data Sheet
 Intel 82368SL-DF Data Sheet
 Intel 82092AA Data Sheet
 Intel Architecture Development Lab - PCI to PCMCIA CardBus Bridge Specification
 O2 Micro 6832/6833/6860 Data Sheets
 Ricoh RF5C266/366 Data Sheet
 Ricoh RF5C296/396 Data Sheet
 Ricoh RF5C466 Data Sheet, Ricoh RF5C476 Data Sheet
 Texas Instruments PCI1050 Data Sheet
 Texas Instruments PCI1130/1131 Data Sheet
 Texas Instruments PCI1031 Data Sheet
 Texas Instruments PCI1220/1250/1221/1210 Data Sheet
 Texas Instruments PCI14xx Data Sheets
 Databook TCIC-2/N Hardware Design Guide/ Databook PCMCIA Design Variations Engineering Report

1.6 Installing the PCCtest Software

The PCCtest software consists of a single executable program. PCT170 EXE is the executable for PCCtest 170. To install the PCCtest software simply copy the PCT170.EXE to your hard disk. The program may also be executed directly from the floppy disk. Also included on the diskette is a READ.ME file containing information on any recent changes in the PCCtest software. Updates to the software may be downloaded from the Sycard Technology WEB page at <http://www.sycard.com>. Technical support may be addressed to support@sycard.com.

2.0. PCCtest Operation

The procedure for testing the desired socket is simple. Inserting the PCCtest unit into the socket and invoke the test program. The test program will execute a variety of tests automatically and return PASS or FAIL status. If any errors are detected, they will be displayed on the screen.

Note: The PCCtest will not operate correctly with Socket and Card Services present. Remove all PCMCIA driver software from AUTOEXEC.BAT or CONFIG.SYS files and re-boot before using PCCtest.

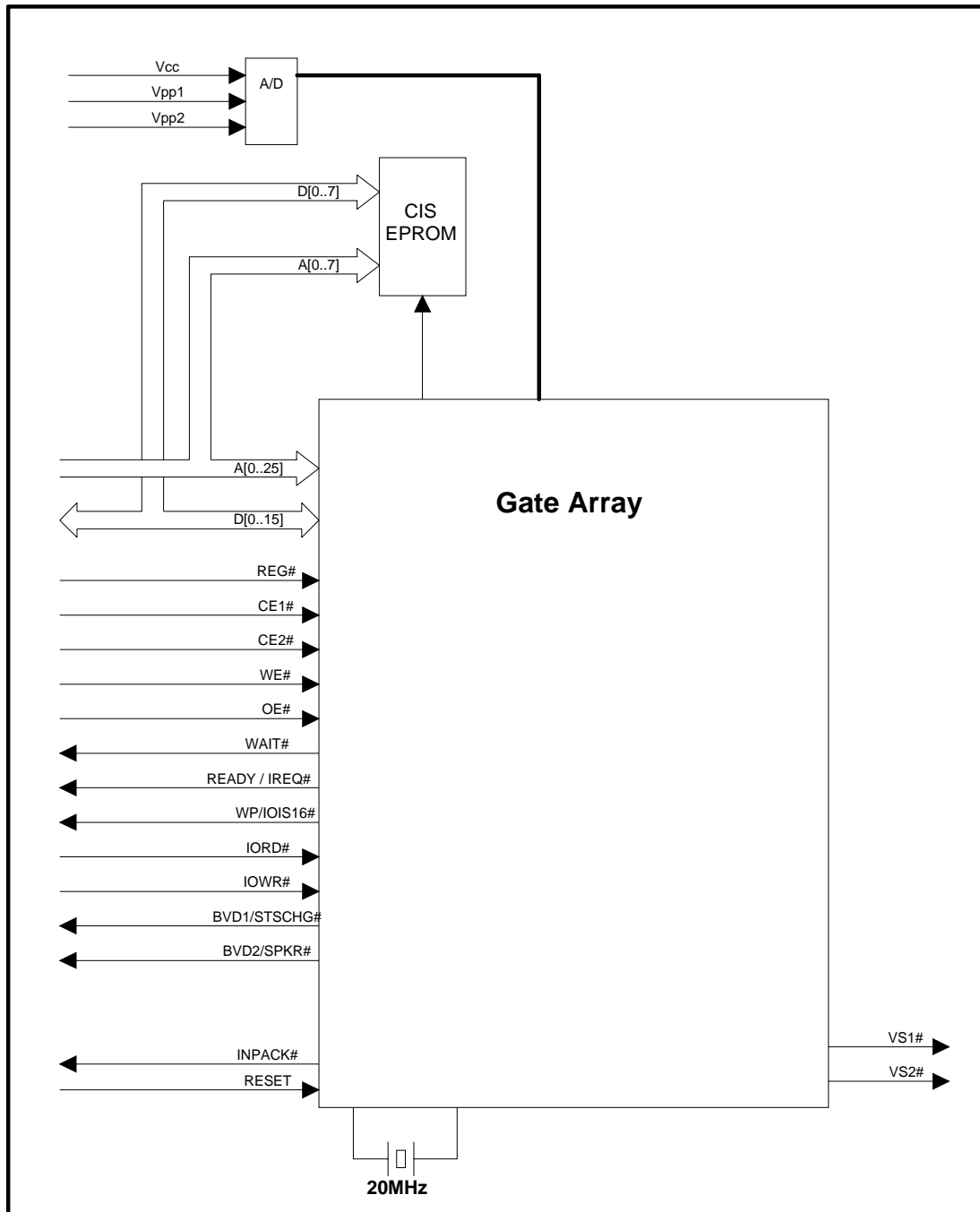

Figure 2.0-1PCCtest 170 Block Diagram

2.1 PCCtest Software

The PCCtest software is a MS-DOS application distributed on a single floppy diskette. PCT170.EXE is for use with the PCCtest 170. Included on the diskette is the test application program, and a READ.ME file containing information not contained in this document. The PCCtest program has the following run time switches:

Syntax

```
PCT170 -0 -1 -2 -3 -a -bxx -c -gx -h -i -j(s)x -k -lx -nxxx -p -q -r -t -v -w -z
```

Switches

-0 Test socket 0 - primary socket controller at base address 3E0-3E1H
 -1 Test socket 1 - primary socket controller at base address 3E0-3E1H
 -2 Test socket 2 - second socket controller at base address 3E0-3E1H
 -3 Test socket 3 - second socket controller at base address 3E0-3E1H
 -ax PCIC Controller address select-a1 = 3E2-3E3H, -a2 = 3E3-3E4H,
 -a3 = 3E5-3E6H
 -bxx(b) Select Socket controller xx = Socket controller b = Select external voltage switch clock for TI
 See section 2.2 for list of currently supported socket controllers
 -c Select common Vpp (Vpp1 = Vpp2)
 -gx Test Vcc select
 -g3 = Test at Vcc = 3.3 volts, -g5 = Test at Vcc = 5.0 volts (default), -ga = Test at Vcc = 3.3/5V
 -hx -h Bypass Vcc and Vpp tests, -h1 No Vpp test, -h2 = No Vcc test
 -i Test INPACK# (Selected socket controllers only)
 -jx Select alternate memory window. -j1 = C800:0 - CFFF:0, -j2 = E000:0 - E7FF:0
 -jsxxxx Select alternate memory window, xxxx = Memory Segment.
 -k Test voltage sense (VS[2:1]#) pins
 (Voltage Sense tests not supported on CardBus controllers)
 -lx Long power on delay (x = integer 1-32768)
 -nxxx Select alternate I/O window address (default = 150H)
 -p Test Vpp at 5V and 12V only (default tests at 0V, 5V and 12V).
 -q Quiet mode - Disables speaker test
 -sx Select PCI chip number. -s2 selects the 2nd occurrence of the selected (-bxx) chip.
 -t 10% tolerance on Vpp measurements. (default is 5%)
 -v Verbose mode. Displays test progress and error messages
 -w 10% tolerance on Vcc measurements (default is 5%)

Note: Switches can be entered in any order and must be separated by a space.

2.1.1 PCCtest Host Software Environment

The PCCtest software is designed to run under MSDOS 3.0 or higher. During the test PCCtest software makes direct I/O and memory accesses to PCCtest resources. Any software or operating system that blocks or allocates resources that conflicts with the PCCtest software will cause the test to fail. See section 3.1 for information on the resources used by the PCCtest software. In Windows 95/98 the PCCtest software should be run in a MSDOS Safe mode. This assures that sufficient upper memory areas are available for the test windows. Operation in a "DOS Box" under windows is not recommended. To enable a Safe mode DOS environment, reboot the computer and enter <F8> as the computer starts to boot. A user can select a MSDOS Safe Mode from the startup menu. For O/S without a Safe mode, try booting with a MSDOS formatted floppy diskette.

2.2 Using the PCCtest Software

Section 2.1 describes the command line switches used to invoke the PCCtest software. If a manual is not handy, the PCCtest software includes a single screen listing of the command line switches. To view this screen, simply enter the PCT170 command without any switches:

```
PCT170<CR>
```

```

Sycard Technology PCCTest 170 software v1.03x 11/21/02  m d b t
PCCTest Help Menu - Page 1/3 Command Line Switches
-0  Select socket 0                -nxxx Alternate I/O Address
-1  Select socket 1                -p    5V/12V Vpp
-2  Select socket 2                -q    Disable Speaker Test
-3  Select socket 3
-ax Socket Controller base addr    -sx   PCI Chip Number
   a1=3E2,a2=3E4,a3=3E8,a4=3E6    -t   10% Vpp Tolerance
-bxx Select Chip Type              -u   Not Used
-c  Common Vpp1 and Vpp2           -v   Verbose - Show Errors
-g  Select Test Voltage            -w   10% Vcc Tolerance
   g3=3.3V, g5=5V, -ga=Both
-h  Disable all Voltage Tests
   h1-No Vpp Test, h2-No Vcc Test
-i  Test INPACK-                   -m$  Enter debug menu
-jx Mem window 1=C800, 2=E000     -mx:y Test option
   jsxxxx Select Segment xxxxx
-k  Test VS pins
-lx Long power-on delay

```

Copyright 1994-2002 Sycard Technology 1180-F Miraloma Way, Sunnyvale, CA 94085
(408)749-0130 (408)749-1323 FAX On the Web at <http://www.sycard.com>
Hit any key for next page, ESC to exit help menu... (Page 1/3)

Page 2 of the help menu

```

Sycard Technology PCCTest 170 software v1.03x 11/21/02
PCCTest Help Menu - Page 2/3 Supported Socket Controllers
-bxy Select chip type
-b40 - Ricoh RF5C266/366          -b41 - Ricoh RF5C296/396
-b42 - Ricoh RF5C466              -b43 - Ricoh RF5C465          -b44 - Ricoh 5C476/476M2
-b45 - Ricoh 5C478/478M2         -b46 - Ricoh 5C475/475A     -b46 - Ricoh R5C521
-b45 - Ricoh R5C522              -b46 - Ricoh R5C551         -b44 - Ricoh R5C552
-b44 - Ricoh R5C554              -b44 - Ricoh R5C576A       -b44 - Ricoh R5C590
-b44 - Ricoh R5C592              -b44 - Ricoh R5C593

-b60-TI PCI1050                  -b61-TI PCI1030            -b62-TI PCI1130**          -b63-TI PCI1131**
-b64-TI PCI1031**                -b65-TI PCI1250**          -b66-TI PCI1220**          -b67-TI PCI1221**
-b68-TI PCI1210**                -b69-TI PCI1225**          -b70-TI PCI1251A**         -b71-TI PCI1450**
-b72-TI PCI1211**                -b73-TI PCI1251B**         -b74-TI PCI4450**          -b75-TI PCI1420**
-b76-TI PCI1410**                -b77-TI PCI1451**          -b78-TI PCI4451**          -b79-TI PCI4410**
-b80-TI PCI1520**                -b82-TI PCI1620**          -b83 TI PCI4510**          -b84-TI PCI7510**
-b85-TI PCI1510**

```

TI PCI12xx,14xx,44xx,15xx,45xx series, 'b' suffix for ext volt switch clock

Copyright 1994-2002 Sycard Technology 1180-F Miraloma Way, Sunnyvale, CA 94085
(408)749-0130 (408)749-1323 FAX On the Web at <http://www.sycard.com>
Hit any key for next page, ESC to exit help menu... (Page 2/3)

Page 3 of the help menu

```

Sycard Technology PCCTest 170 software v1.03x 11/21/02
PCCTest Help Menu - Page 3/3 Supported Socket Controllers
-bxy Select chip type
-b10 - Cirrus CL/PD6710/20       -b11 - Cirrus 6722          -b12 - Cirrus 6729
-b13 - Cirrus CL/PD6730         -b14 - Cirrus 6832          -b16 - Cirrus 6833
-b20 - Vadem VG-365             -b21 - VG-465/468          -b22 - Vadem VG-469
-b30 - Intel 82365SL-DF         -b31 - Intel 82092AA (PPEC)

```

```

-b50 - VLSI 82C146          -b51 - VLSI 82C146A

-ba0-O2 OZ6832C          -ba2-O2 OZ6836C          -ba3-O2 OZ6860          -ba4-O2 OZ6833
-ba5-O2 OZ6812          -ba6-O2 OZ6933          -ba7-O2 OZ6912/711E0   -ba8-O2 OZ6922
-ba6-O2 OZ711E1          -ba9-O2 OZ711EC1/M1     -baa-O2 OZ711EC1       -bab-O2 OZ711M1
-bac-O2 OZ711E2          -bad-O2 OZ711M2         -bae-O2 OZ711M3        -baf-O2 OZ6933E

-bc0-ENE 1225           -bc1-ENE 1420           -bc2-ENE 1211           -bc3-ENE 1410
-bc5-ENE 710            -bc6-ENE 720

```

ENE PCI12xx,14xx series, 'b' suffix for ext volt switch clock

Copyright 1994-2002 Sycard Technology 1180-F Miraloma Way, Sunnyvale, CA 94085
(408)749-0130 (408)749-1323 FAX On the Web at <http://www.sycard.com>

Hit any key for next page, ESC to exit help menu... (Page 3/3)

Before attempting to test the PC Card socket, the user must first determine several parameters about their socket. The first item to determine is the vendor and part number of the socket controller. Verify that the socket controller is supported in the list shown in the help screen. If the part is not listed, call Sycard Technology for testing information. The second step is to start building the command line string used to invoke the PCCtest software. The user must specify the slot number, the various test options and display options. For example, when testing the Vadem VG-468 the following command line is used. This command line will test slot 1 of the VG-468 and display the test progress and all errors. The -c option specifies common Vpp control.

PCT170 -b21 -v -1 -c<CR>

```

Sycard Technology PCCtest 170 software v1.03
Testing Slot 1
Socket Controller = Vadem VG-465/468
Checking Socket Controller.....Passed
Power on delay (Vcc = 5 volt).....Complete
Basic operational test.....Passed
Data pattern test.....Passed
Address pattern test.....Passed
Status bit pattern test.....Passed
Wait bit test.....Passed
Reset test.....Passed
Card voltage test.....Passed
Audio out test.....Complete
Test completed with 0 errors - PASSED

```

Example 1 - Testing the Vadem VG-468

The Vadem VG-468 is a single chip, dual socket PC Card controller. The VG-468 supports PCMCIA's release 2.1 specification and therefore does not support 3.3V, DMA or voltage sense pins. The VG-468 is fully compatible with the Intel 82365SL and supports dual independent VPP per socket. The following examples illustrate various command line options used to test the various system implementation of the VG-468.

1. GO/NO-GO test of slot 0 of a dual slot portable computer using the Vadem VG-468. PC Card slot has independent Vpp control with dual levels (5V and 12V). The following command line will execute the test on slot 0 and suppress error listings. A final Pass/Fail message will be output after the test is complete.

```
PCT170 -0 -b21 -p

Sycard Technology PCCtest 170 software v1.03
Testing Slot 1
Socket Controller = Vadem VG-465-468
Test completed with 0 errors - PASSED
```

2. The following command line is for testing slot 1 of another VG-468 based portable. The PC Card slot has common Vpp control with three levels (0V, 5V and 12V). The following command line will test card detects and INPACK#.

```
PCT170 -1 -b20 -v -c -i<CR>

Sycard Technology PCCtest 170 software v1.03
Testing Slot 1
Socket Controller = Vadem VG-465/468
Checking Socket Controller.....Passed
Power on delay (Vcc = 5 volt).....Complete
Basic operational test.....Passed
Data pattern test.....Passed
Address pattern test.....Passed
Status bit pattern test.....Passed
Wait bit test.....Passed
Reset test.....Passed
INPACK test.....Passed
Card voltage test.....Passed
Audio out test.....Complete
Test completed with 0 errors - PASSED
```

Example 2 - Testing the Cirrus Logic CL-PD6722

3. GO/NO-GO test of a dual slot portable computer using the Cirrus Logic CL-PD6720. Since the Cirrus 672x series only supports common Vpp (Vpp1=Vpp2), the PCCtest software will automatically set the common Vpp option (-c) when the CL-PD6722 is selected. Vpp supports three levels (0V, 5V, and 12V).

```
PCT170 -0 -b11 -v <CR>

Sycard Technology PCCtest 170 software v1.03
Testing Slot 1
Socket Controller = Cirrus 6722
Checking Socket Controller.....Passed
Power on delay (Vcc = 5 volt).....Complete
Basic operational test.....Passed
Data pattern test.....Passed
Address pattern test.....Passed
Status bit pattern test.....Passed
Wait bit test.....Passed
Reset test.....Passed
Card voltage test.....Passed
Audio out test.....Complete
Test completed with 0 errors - PASSED
```

Example 3- Embedding PCCTEST.EXE in a Batch File

PCT170.EXE can be embedded in a batch file or called from a test executive. The following illustrates a batch file that will continue to test socket 0 until a failure is detected.

```
echo off
:loop
PCT170 -0 -b11 -v
if errorlevel 1 goto exit
goto loop
:exit
echo on
```

2.3 Testing 3.3V Operation

The PCCtest 170 is capable of running at 3.3V and 5.0V. The following socket controllers support 3.3V operation when used with the PCT170.EXE software.

- Cirrus Logic CL-PD6710/20/22/29/30
- Cirrus Logic CL-PD6832
- ENE CardBus Controllers
- Intel 82365SL-DF
- Omega Micro 82C094/80C196
- O2 Micro OZ6832/OZ6836/OZ6860/OZ6833/OZ6812/OZ69xx
- Ricoh RF5C266/366/296/396
- Ricoh CardBus Controllers

- Texas Instruments PCI1050/1030/1031
- Texas Instruments CardBus Controllers
- Vadem VG-469
- VLSI 82C146/146A

It is important to note that while these chips support 3.3V operation, multiple Vcc support is a system design option. Before attempting to test 3.3V operation, the user should determine if the host adapter design supports it.

The **-gx** switch specifies the operational voltage of the test. The **-gx** option in conjunction with the chip type (**-bxx** switch) will determine how the software controls the power control bits in the socket controller. The **-g3** or **-ga** options are only valid when used with chips that support 3.3 volt operation. These are as follows:

- g3** specifies that the full test will be run at 3.3V
- g5** specifies that the full test will be run at 5.0V (Default if option is not specified)
- ga** specifies that the first portion of the test will be run at 5.0V. After the 5.0V portion of the test has been completed, the software will power-down the slot and re-power the slot at 3.3V. The software will then verify that the slot power has correctly been changed by running the Vcc measurement portion of the test.

If the **-g3** or **-g5** option is specified, the PCT270.EXE will display at which voltage Vcc is set during the testing process:

```
If -g5 or -gx not specified:
    Power on delay (Vcc = 5 volt).....Complete

If -g3 specified:
    Power on delay (Vcc = 3.3 volt).....Complete
```

If the **-ga** option is specified, the PCT270.EXE will complete the full test at Vcc=5 volts and then re-power the interface to 3.3 volts and command the PCCtest's microcontroller to measure the Vcc voltage. The following output shows the test progress when the following command line is specified:

```
PCT170 -1 -b11 -v -ga<CR>

Sycard Technology PCCtest 170 software v1.03
Testing Slot 1
Socket Controller = Cirrus 6722
Checking Socket Controller.....Passed
Power on delay (Vcc = 5 volt).....Complete
Basic operational test.....Passed
Data pattern test.....Passed
Address pattern test.....Passed
Status bit pattern test.....Passed
Wait bit test.....Passed
Reset test.....Passed
Card voltage test.....Passed
Audio out test.....Complete
Power on delay (Vcc = 3.3 volt).....Complete
Card voltage test (Vcc = 3.3 volt).....Passed
Test completed with 0 errors - PASSED
```

2.4 Testing the Voltage Sense Pins

PCMCIA's Release 5.0 Standard specifies two pins as Voltage Sense pins. These pins are driven by the PC Card and specify the initial power-up voltage to be applied to the card. When the Voltage Sense option is enabled (**-k** option), the PCT170.EXE software will force the PCCtest card to drive VS1# and VS2# to their active, then inactive states. Only a

few of the newer socket controllers support VS1# and VS2#. Several controllers only support VS1# and not VS2#. The following table lists the VS1# and VS2# support for various socket controllers:

Vendor	Socket Controller	VS1	VS2
Cirrus Logic	CL-PD6722	Yes	No
Cirrus Logic	CL-PD6729/30	Yes	Yes
Intel	82092AA (PPEC)	Yes	Yes
Omega / Trident	82C722G	Yes	No
Omega / Trident	82C094	Yes	Yes
Ricoh	RF5C296/396	Yes	No
Texas Instruments	PCI1050	Yes	Yes
VLSI	82C146A	Yes	No

Table 2.5-1 Socket Controller Voltage Sense Support

The **-k** option in conjunction with the chip type (**-bxx** switch) will determine how the software monitors the status of the VS pins.

Note: Voltage Sense testing not supported on CardBus controllers

2.5 Testing the Input Acknowledge Pin (INPACK#)

All PCCtest socket testers are capable of testing INPACK#. However, INPACK# is not supported on many socket controllers including the industry standard Intel 82365SL. The PCCtest software supports INPACK# testing on the following socket controllers:

- Vadem VG-465/468/469
- Cirrus Logic CL-PD6710/20/22
- Ricoh RF5C296/396
- Databook 82082

INPACK# testing is enabled via the **-i** switch. The **-i** option in conjunction with the chip type (**-bxx** switch) will determine how the software controls the enabling of INPACK# in the socket controller.

Note: INPACK# testing not supported on CardBus controllers

Note: Revision 1.00 of the PCCtest 170 does not support INPACK# testing

2.6 Testing PCI-PCMCIA Controllers

The PCCtest software is designed to test several different PCI-PCMCIA based socket controllers. The user simply selects the appropriate socket controller using the **-bxx** switch. If the selected socket controller is PCI based, the PCCtest software will automatically search the PCI bus for the selected chip. All accesses to PCI hardware are via the host's PCI BIOS.

Note: PCCtest software will not work with hosts that do not provide PCI BIOS support. A message similar to the following will be returned if a PCI BIOS is not present:

```
Sycard Technology PCCtest 170 software v1.03
Looking for Cirrus 6729 PCI Controller #1...
Error! - PCI BIOS not present
```

Once PCCtest software detects the presence of a PCI BIOS, it will search the PCI bus for the selected socket controller. If the software detects the socket controller, it will place the socket controller chip into an Intel 82365SL compatible I/O address space (3E0/3E1H).

*Note: PCI socket controllers will be placed in an 82365SL compatible 3E0/3E1H I/O address space. No other addresses are supported. The **-ax** option will have no effect in a PCI environment.*

```
PCT170 -b12 -1 -v -ga<CR>

Sycard Technology PCCtest 170 software v1.03
Looking for Cirrus 6729 PCI Controller #1...
  Cirrus CL-PD6729 Found at Bus 00, Function 00, Device 0E
  Cirrus CL-PD6729 Successfully Configured for I/O address 3E0/3E1
Testing Slot 1
Socket Controller = Cirrus 6729/30
Checking Socket Controller.....Passed
Power on delay (Vcc = 5 volt).....Complete
Basic operational test.....Passed
Data pattern test.....Passed
Address pattern test.....Passed
Status bit pattern test.....Passed
Wait bit test.....Passed
Reset test.....Passed
Voltage Sense.....Passed
Card voltage test.....Passed
Audio out test.....Complete
Power on delay (Vcc = 3.3 volt).....Complete
Card voltage test (Vcc = 3.3 volt).....Passed
Test completed with 0 errors - PASSED
```

2.8 Notes On Vpp Testing

The method in which the programming voltage (Vpp) is switched to the PC Card socket depends on the socket controller chip and the system design. There are two Vpp pins on the 68 pin PC Card interface, Vpp1 and Vpp2. On the host side, these pins can be tied together and supplied by a single power source (common) or left independent with two power sources (independent). The Vpp power supply can typically support two or more voltage levels. Most designs can support two (Vcc, and 12V) or three (0V, Vcc and 12V) levels. In a majority of designs system designers provide a single common Vpp supply that supports three levels (0V, Vcc and 12V). However, there are many designs that deviate from this de-facto standard. The PCCTEST software supports all combinations of Vpp support with a **-c** and **-p** option. The following table lists the various socket controllers and their Vpp support capabilities.

Vendor	Socket Controller	Independent	Common	-c option available	-p option available
Cirrus Logic	CL-PD6710/20/22	NO	YES	NO	YES
Cirrus Logic	CL-PD6729/30	NO	YES	NO	YES
Cirrus Logic	CL-PD6832	NO	YES	NO	YES
Intel	82365SL	YES	YES	YES	YES
Intel	82365SL-DF	NO	YES	NO	YES
Omega /Trident	82C722/094	NO	YES	NO	YES
O2 Micro	CardBus	NO	YES	NO	YES
Ricoh	RF5C266/366	NO	YES	NO	YES
Ricoh	RF5C296/396	NO	YES	NO	YES
Ricoh	CardBus	NO	YES	NO	YES
Texas Inst	PCI1050	NO	YES	NO	YES
Texas Inst	PCI1130/1131	NO	YES	NO	YES
Texas Inst	CardBus	NO	YES	NO	YES
Texas Inst	PCI1031	NO	YES	NO	YES
Vadem	VG-365	YES	YES	YES	YES
Vadem	VG-465/468	YES	YES	YES	YES
Vadem	VG-469	NO	YES	NO	YES
VLSI	82C146/146A	NO	YES	NO	YES

Table 2.8-1 Socket Controller Vpp support

Note: Most newer socket controllers only support common Vpp control.

2.8.1 Common vs. Independent Vpp Control

The Intel 82365SL socket controller supports independent Vpp control. This means that Vpp1 and Vpp2 can be individually controlled. This support required two pins per Vpp supply. Newer socket controllers, in an effort to reduce pin-count, combined Vpp1 and Vpp2 control (common Vpp). Socket controllers that support Independent Vpp control can be configured as independent or common Vpp, depending on the system design. The user of the PCCtest socket controller must determine if the socket supports independent or common Vpp. Table 2.8-1 summarizes the Vpp support of the various socket controllers. If the column in the “-c option available” is labeled “YES,” then the corresponding socket controller can have either common or independent Vpp control.

The following error message can be associated with either incorrectly specifying the -c or omitting the -c option.

```
Card voltage test.....
Vpp2 tolerance error (12V) = 0.00)
Vpp2 tolerance error (5V) = 0.00)
```

2.8.2 Two vs. Three Level Vpp Control

Most Vpp switch designs allow the socket to supply 0V, Vcc and 12V to the socket. In order to reduce cost, some designers have opted for two-level Vpp control (Vcc and 12V). The PCT170 -p switch configures the software to test two levels of Vpp instead of three. The following error message is output when the -p switch is not specified when testing a socket with two-level Vpp:

```
Card voltage test.....
Vpp1 tolerance error (0V) = 5.00)
Vpp2 tolerance error (0V) = 5.00)
```

2.9 Testing CardBus Controllers

CardBus controllers support both 16-bit and 32-bit (CardBus) operation. The PCCtest 170 socket tester supports testing of the 16-bit portion of the CardBus controller chip. The following signals cannot be tested by the PCCtest 170 series on a CardBus controller:

- CD1- and CD2-
- VS1 and VS2
- -INPACK

For testing the 32-bit portion of the interface, Sycard recommends the PCCtest 460 series of CardBus socket testers. The PCCtest 460 supports 16-bit, CardBus and Zoomed video testing. Contact Sycard Technology for more details.

***Note:** CardBus socket controllers from TI may require a special option switch depending on the hardware implementation of the external voltage switch. See appendix C for complete details.*

3.0 Hardware Notes

The PCCTEST software is designed to test the Intel PCIC and compatible architectures. Both sockets on the primary and secondary adapter at I/O address 3E0/3E1H can be tested. The -a option allows testing of controllers at the primary, secondary, etc. addresses.

Note: VLSI Technology 82C146 host socket controller each controls a single PC card socket. Because of the chip's architecture, each socket controller has an independent index and data register. The following table lists the I/O addresses and the Index offsets for a typical configuration:

Socket	I/O Address	Index Range	PCCtest switches
0	3E0/3E1H	00 to 3FH	-0
1	3E4/3E5H	80 to BFH	-2 -a2
2	3E2/3E3H	00 to 3FH	-0 -a1
3	3E6/3E7H	80 to BFH	-2 -a3

Table 2.2-1VLSI Technology 82C146/146A socket mapping

Note: PCCtest supports the Databook controllers at an I/O address 240H only.

3.1 System Resource Required

The PCT170 software requires certain I/O and memory address space resources to carry out its test. For the full duration of the test, the PCCtest program will open up an I/O window at 150-15FH. The -nxxx option allows the user to specify an alternate 16 byte I/O window. In addition, a 32K byte memory window at D000:0 - D7FF:F is used for common and attribute memory testing. The -jx or the -jsxxxx option allows the user to specify an alternate memory mapped window. The user must verify that other users of high memory, such as EMS drivers, do not use the D000:0 - D7FF:F area.

4.0 Test Coverage

PCCtest is designed to provide high test coverage of the PC Card interface. This document will detail the test procedure used to test the PC Card interface and provide information on the test coverage.

4.1 Test Subsections

The PCCtest software is designed to run under a DOS environment in a PC architecture machine. A simple command line invocation starts the PCCtest software. Several command line options configure the test for host options. The following output illustrates the test flow for the PCCtest software.

```
Sycard Technology PCCtest software v1.03
Testing Slot 1
Socket Controller = Cirrus 6722
Checking Socket Controller.....Passed
Power on delay (Vcc = 5 volt).....Complete
Basic operational test.....Passed
Data pattern test.....Passed
Address pattern test.....Passed
Status bit pattern test.....Passed
Wait bit test.....Passed
Reset test.....Passed
INPACK test.....Passed
Voltage Sense.....Passed
Card voltage test.....Passed
Audio out test.....Complete
Test completed with 0 errors - PASSED
```

The following sections will describe the tests performed in each test module.

4.1.1 Socket Controller Verification - Test 1

The Socket Controller verification test is intended to provide a basic read/write test of the socket controller's registers. 8 bit read/write tests with all data patterns and verifies the connection of the data bus, system I/O read and write strobes and addressing required to access the socket controllers registers. This test is not designed to test the functionality of the socket controller, but only to verify sufficient operation to continue the test of the socket interface. If this test fails, it indicates that communication between the systems and socket controller's registers and no further testing is possible.

4.1.2 Basic Operational Test - Test 2

The first part of the Basic Operational test verifies that after a power-on delay, card detects are active. If CD1# and CD2# are not low, then the card is not inserted or the card slot is not powered and further testing is not possible. Once card detects are active the Basic Operational Test tests basic read/write functionality of the interface. This test insures that the PC Card interface has enough functionality to continue with the reset of the tests.

- 1 8 bit I/O write/read test with the following patterns - 00H, AAH, 55H,5AH,FFH and 11H.
- 2 16 bit I/O write/read test with the following patterns - 0000H, AAAAH, AA55H, 55AAH, FFFFH and 1234H.
- 3 16 bit memory write/read test with the following patterns - 0000H, AAAAH,AA55H, 55AAH, FFFFH and 1234H.
- 4 Memory - I/O transfer test - Verifies that a pattern can be written via a memory write and read back via an I/O read. This test will verify if EMS or other memory is mapped to the PC Card memory window. If an error occurs, a message similar to the following will be returned:
ERROR! - Check EMS or other high memory conflict.

4.1.3 Data Pattern Test - Test 3

The Data Pattern Test is designed to test a full range of data patterns.

- a. Walking 1 pattern
- b. Walking 0 pattern
- c. 64K patterns.

4.1.4 Address Pattern Test - Test 4

The Address Pattern Test utilizes the PCCtest's address latches. Addresses are latched on the PCCtest's on-board address latches and read back and compared with the address accessed. All 26 address and the REG# signal are latched. The address test consists of the following:

- a. Walking 1 pattern
- b. Walking 0 pattern
- c. 64K patterns on lower address lines
- d. 64K patterns on upper address lines

4.1.5 Status Bit Pattern Test - Test 5

Status bit pattern test is designed to test the following status bits:

BVD1/STSCNG#
BVD2/SPKR#
WP/IOIS16#
READY/IREQ#

A series of patterns is setup on the PCCtest's output latch and read back through the socket controller's status register.

4.1.6 Wait Bit Test - Test 6

The Wait Bit Test tests the WAIT# signal. WAIT# is tested for both I/O and memory accesses. Utilizing the PCCtest's timing measurement circuit, the PCCtest program will measure the duration of a zero wait state I/O and memory read. The socket controller's wait state generator is setup to add 700ns of wait states. The measurement circuit is armed and both I/O and memory strobes are measured with the added wait states and compared to the zero wait state access. If wait states are added, the test passes.

Note: If a basic (non-wait state) I/O or memory cycle time is greater than 700nS, the wait bit test will be bypassed.

4.1.7 Reset Test - Test 7

The Reset Test tests the RESET signal. RESET will be forced low, then high. The status will be verified through the PCCtest's status register.

4.1.8 INPACK Test - Test 8 (optional)

The INPACK Test tests the INPACK# signal. The software will instruct the PCCtest card to assert INPACK# on any I/O read. Software will then configure the particular socket controller to enable INPACK# operation. See section 2.5 for a listing of socket controllers that support INPACK#.

4.1.9 Voltage Sense Pins - Test 9

The PC Card '95 standard specifies two pins as Voltage Sense pins, VS1# and VS2#. These pins are driven by the PC Card and specify the initial power-up voltage to be applied to the card. When the Voltage Sense option is enabled (-k option), the PCCTEST software will force the PCCtest card to drive VS1# and VS2# to their active, then inactive states. See section 2.4 for a listing of socket controllers that support VS1 and VS2.

4.1.10 Card Voltage Test - Test 10

The Card Voltage Test utilizes the PCCtest's internal A/D converter. The A/D converter is capable of measuring Vcc, Vpp1 and Vpp2. Vcc is measured with a 5% tolerance. An optional switch allows 10% tolerance for Vcc. Vpp1 and Vpp2 can usually be set to two or three levels. Software switch options allow the test to be configured for the appropriate Vpp configurations.

Switch	Name	Description
-c	Common Vpp	Vpp1 and Vpp2 on host tied together
-p	Two level Vpp	Vpp only capable of 5V and 12V levels. Otherwise three level (0V, 5V and 12V)
-t	10% Vpp tolerance	Vpp checked to 10% tolerance (Not recommended)
-w	10% Vcc tolerance	Vcc checked to 10% tolerance (Not recommended)

Table 4.1-1 Voltage Measurement options

Note: When common Vpp option selected, both Vpp1 and Vpp2 will be tested.

4.1.11 Audio Out Test - Test 11

The audio out test utilizes the PCCtest internal 1KHZ audio generator. A 1 second 1KHZ burst will be placed on the -SPKR signal to test the host system's speaker circuit. The -q option disables the Audio Out test.

4.2 Test Coverage Table

Pin	Name	Description	Test	Pin	Name	Description	Test
1	GND	Ground		35	GND	Ground	
2	D3	Data Bit 3	2,3,10	36	CD1#	Card Detect 1	
2,3	D4	Data Bit 4	2,3,10	37	D11	Data Bit 11	2,3
4	D5	Data Bit 5	2,3,10	38	D12	Data Bit 12	2,3
5	D6	Data Bit 6	2,3,10	39	D13	Data Bit 13	2,3
6	D7	Data Bit 7	2,3,10	40	D14	Data Bit 14	2,3
7	CE1#	Card Enable 1	2,3,10	41	D15	Data Bit 15	2,3
8	A10	Address Bit 10	4	42	CE2#	Card Enable 2	2,3
9	OE#	Output Enable	2,3	43	VS1	Voltage Sense 1	9
10	A11	Address Bit 11	4	44	IORD#	I/O Read Strobe	2,3,10
11	A9	Address Bit 9	4	45	IOWR#	I/O Write Strobe	2,3,10
12	A8	Address Bit 8	4	46	A17	Address Bit 17	4
13	A13	Address Bit 13	4	47	A18	Address Bit 18	4
14	A14	Address Bit 14	4	48	A19	Address Bit 19	4
15	WE#	Write Enable	2,3	49	A20	Address Bit 20	4
16	READY IREQ#	Ready/Busy Interrupt Request	5	50	A21	Address Bit 21	4
17	VCC	Card Power	10	51	VCC	Card Power	10
18	VPP1	Programming Supply Voltage 1	10	52	VPP2	Programming Supply Voltage 2	10
19	A16	Address Bit 16	4	53	A22	Address Bit 22	4
20	A15	Address Bit 15	4	54	A23	Address Bit 23	4
21	A12	Address Bit 12	4	55	A24	Address Bit 24	4
22	A7	Address Bit 7	4	56	A25	Address Bit 25	4
23	A6	Address Bit 6	4	57	VS2	Voltage Sense 2	9
24	A5	Address Bit 5	4	58	RESET	Card Reset	7
25	A4	Address Bit 4	4	59	WAIT#	Extend Bus Cycle	6
26	A3	Address Bit 3	4	60	INPACK#	Input Port Acknowledge	8
27	A2	Address Bit 2	4	61	REG#	Register Select	4,10
28	A1	Address Bit 1	4	62	BVD2/ SPKR#	Battery Voltage Detect 2 Speaker	5,11
29	A0	Address Bit 0	4	63	BVD1/ STSCHG#	Battery Voltage Detect 1 Status Change	5
30	D0	Data Bit 0	2,3	64	D8	Data Bit 8	2,3
31	D1	Data Bit 1	2,3	65	D9	Data Bit 9	2,3
32	D2	Data Bit 2	2,3	66	D10	Data Bit 10	2,3
33	WP/ IOIS16#	Write Protect	5	67	CD2#	Card Detect 2	
34	GND	Ground		68	GND	Ground	

5.0 Common Problems

This section will describe some of the common problems encountered while trying to use the PCCtest socket tester on a known good host socket.

Interference with Card or Socket Services - Card and Socket Services must be disabled for the PCCtest unit to work correctly. The PCCtest software must have full control over the socket controller hardware.

Interference with EMS drivers - EMS drivers may use upper memory resources that conflict with the PCCtest software. PCCtest requires the memory range from D000:0 to D7FFH during the test. Refer to your EMS driver documentation for information on excluding this memory range.

Interference from Core Logic BIOS shadowing - Make sure that your core logic is not shadowing high memory in the range from D000:0 to D7FF:0. Check your BIOS setup.

Socket Controller Test Fails - Socket controller not found. If this test fails, no further testing is possible. There are several possible problems:

1. User did not specify the correct socket
2. User did not specify the correct socket controller
2. Socket controller may be at a non-standard I/O address
3. Socket controller may not be PCIC compatible

Note: The PCCtest unit does not need to be inserted for the Socket Controller test to pass.

Basic Test Fails - The basic test attempts simple I/O and memory read/write patterns. A failure here will prevent further testing. A failure on a known good socket can be caused by the following:

1. PCCtest unit not inserted into the correct socket.
2. Non-standard socket controller
3. Card and Socket Services enabled
4. EMS driver allocating D000:0 memory space.
5. Chipset setup shadowing D000:0 memory space.
6. ISA Bus speed too high. Set the ISA bus speed to 8.33MHz

Vpp tests fail - There are several configurations for Vpp control in existence. The **-c**, **-p**, **-t** options should be able to configure PCCTEST for your particular configuration. Also make sure that the correct socket controller is being selected with the **-bxx** option. See section 2.8 for a discussion of Vpp and Vcc tests.

Basic Test Failures - Card Detect Failure - Verify if power is being applied to slot during test. PCCtest software will attempt to apply power to slot. After a power-on delay, the PCCtest unit will assert card detects. If no card detect are detected after this short delay, then check to see if power is being applied to socket.

Signal Quality Problems - These problems usually appear as address pattern or data pattern test failures. These problems can appear as random or pattern related. See section 7.4 for a discussion on signal quality problems.

Using the Wrong PCCtest Software - PCCtest 170 should only use the PCT170 software. The PCCtest 170 is not compatible with Sycard's PCCtest 2xx, 3xx or 4xx series of socket testers.

5.1 Test Failures

The type of test failure can point to a specific problem or a general area.

Failure Type	Description of Possible Error Conditions
Socket Controller Failure	The host interface to the socket controller is not working. This can be related to a number of problems from open or shorted pins to incorrect addressing. The socket controller test only accesses the registers in the host socket controller and not the PCCtest hardware.
Card Detect Error	Card Detects are not active. Can be caused by a variety of problems: <ol style="list-style-type: none"> 1. Card Detect Pins open - Check PCB, solder joints or bent pins 2. Not specifying the -bxx option correctly.
Basic Test	Basic Read/Write operation to the PCCtest. Executes a simple I/O and memory read/write test. A failure on this test may be related to one of the following: <ol style="list-style-type: none"> 1. Problem with IORD#, IOWR#, OE#, WE#, CE1#, CE2# 2. Problem with A0, A1 or A2 3. Problem with D[0-15] 4. Socket Controller address mapping problem 5. Power supply problem 6. Socket Services not disabled
Data Pattern Test	Data Pattern Test - Data pattern failures can be caused by the following problems: <ol style="list-style-type: none"> 1. Open or shorted data signals 2. Signal quality problems (See section 5.3)
Address Pattern Test	Address Pattern Test - If only one or two bits of error, the usual cause is shorted or open address pins. If many bits are failing, then several possibilities exist: <ol style="list-style-type: none"> 1. Socket Services not disabled 2. EMS mapping not disabled in D000:0 D7FF:F range 3. BIOS shadowing not disabled in the D000:0 to D7FF:F range 4. Signal quality problems (See section 5.3)
Status Bit Pattern Test	Tests the following bits, BVD1, BVD2, WP and READY.
Wait Bit Test	Verifies that the WAIT# bit extends the I/O or memory cycle. Failure of this test indicates one of the following: <ol style="list-style-type: none"> 1. WAIT# signal has no effect, either open WAIT# line or socket controller wait logic not working. 2. Basic (non-wait state) cycle is greater than 700ns. PCCtest can only insert a 700ns wait state.
Reset Test	Test the RESET signal. RESET will be forced low then high.
Card Voltage Test	Verifies the Vcc and Vpp supplies.
Audio Out Test	The Audio Out test will always pass. It simply outputs a 1KHz tone to the SPKR# pin on the PC Card interface. The PCCtest software assumes that the SPKR# pin is connected to audio driver circuits. Socket controllers that require the enabling of the SPKR# output are not supported by the PCCtest software.

Once the error has been detected with the PCCtest software, debugging may begin. The following sections describe the procedure for various failures. The PCCtest software contains a simple debugging routine that may assist in finding the problem. To enter the PCCtest debugging mode add **-m\$** to the command line.

5.3 Signal Quality and Noise Problems

A very common problem with the PC Card interface is related to noise and signal quality. The large number of simultaneously switching signals creates a large load on the ground and power pins. Socket controller vendors try to reduce the problem through slew rate limiting and double-bonding of power pins. The designer must use proper grounding and signal conditioning techniques to insure that the interface complies with the PC Card specification. The PC Card Specification states that the interface signals remain within 0.0 volts and Vcc+0.25 volts.

One of the most common signal quality problem is over and under shoot on the interface signals. The PC Card Specification dictates that the maximum Vih be no higher than Vcc+0.25 volts and the Vil be no lower than -0.3volts.

Operation beyond these limits often times cause unreliable and unexpected errors with the PCCtest series of socket testers.

Why the problem? CMOS I/O pins are clamped against Vcc and Ground through protection diodes. When the input voltage exceeds Vcc, the Vcc protection diode will start conducting. The current induced through this clamping action may be quite high (depending on the magnitude over Vcc or below ground). This current may effect adjacent logic areas and cause unpredictable failures.

Caution: Do not ignore these failures. While many PC cards are tolerant of such over and undershoots, many are not.

Appendix A – PC Card-16 Interface

PC Card Pinout - Memory Mode

Pin	Name	Description	Pin	Name	Description
1	GND	Ground	35	GND	Ground
2	D3	Data Bit 3	36	CD1#	Card Detect 1
3	D4	Data Bit 4	37	D11	Data Bit 11
4	D5	Data Bit 5	38	D12	Data Bit 12
5	D6	Data Bit 6	39	D13	Data Bit 13
6	D7	Data Bit 7	40	D14	Data Bit 14
7	CE1#	Card Enable 1	41	D15	Data Bit 15
8	A10	Address Bit 10	42	CE2#	Card Enable 2
9	OE#	Output Enable	43	VS1#	Voltage Sense 1
10	A11	Address Bit 11	44	RFU	Reserved
11	A9	Address Bit 9	45	RFU	Reserved
12	A8	Address Bit 8	46	A17	Address Bit 17
13	A13	Address Bit 13	47	A18	Address Bit 18
14	A14	Address Bit 14	48	A19	Address Bit 19
15	WE#	Write Enable	49	A20	Address Bit 20
16	READY	Ready/Busy	50	A21	Address Bit 21
17	VCC	Card Power	51	VCC	Card Power
18	VPP1	Programming Supply Voltage 1	52	VPP2	Programming Supply Voltage 2
19	A16	Address Bit 16	53	A22	Address Bit 22
20	A15	Address Bit 15	54	A23	Address Bit 23
21	A12	Address Bit 12	55	A24	Address Bit 24
22	A7	Address Bit 7	56	A25	Address Bit 25
23	A6	Address Bit 6	57	VS2#	Voltage Sense 2
24	A5	Address Bit 5	58	RESET	Card Reset
25	A4	Address Bit 4	59	WAIT#	Extend Bus Cycle
26	A3	Address Bit 3	60	RFU	Reserved
27	A2	Address Bit 2	61	REG#	Register Select
28	A1	Address Bit 1	62	BVD2	Battery Voltage Detect 2
29	A0	Address Bit 0	63	BVD1	Battery Voltage Detect 1
30	D0	Data Bit 0	64	D8	Data Bit 8
31	D1	Data Bit 1	65	D9	Data Bit 9
32	D2	Data Bit 2	66	D10	Data Bit 10
33	WP	Write Protect	67	CD2#	Card Detect 2
34	GND	Ground	68	GND	Ground

PC Card Pinout - I/O Mode

Pin	Name	Description	Pin	Name	Description
1	GND	Ground	35	GND	Ground
2	D3	Data Bit 3	36	CD1#	Card Detect 1
3	D4	Data Bit 4	37	D11	Data Bit 11
4	D5	Data Bit 5	38	D12	Data Bit 12
5	D6	Data Bit 6	39	D13	Data Bit 13
6	D7	Data Bit 7	40	D14	Data Bit 14
7	CE1#	Card Enable 1	41	D15	Data Bit 15
8	A10	Address Bit 10	42	CE2#	Card Enable 2
9	OE#	Output Enable	43	VS1#	Voltage Sense 1
10	A11	Address Bit 11	44	IORD#	I/O Read Strobe
11	A9	Address Bit 9	45	IOWR#	I/O Write Strobe
12	A8	Address Bit 8	46	A17	Address Bit 17
13	A13	Address Bit 13	47	A18	Address Bit 18
14	A14	Address Bit 14	48	A19	Address Bit 19
15	WE#	Write Enable	49	A20	Address Bit 20
16	IREQ#	Interrupt Request	50	A21	Address Bit 21
17	VCC	Card Power	51	VCC	Card Power
18	VPP1	Programming Supply Voltage 1	52	VPP2	Programming Supply Voltage 2
19	A16	Address Bit 16	53	A22	Address Bit 22
20	A15	Address Bit 15	54	A23	Address Bit 23
21	A12	Address Bit 12	55	A24	Address Bit 24
22	A7	Address Bit 7	56	A25	Address Bit 25
23	A6	Address Bit 6	57	VS2#	Voltage Sense 2
24	A5	Address Bit 5	58	RESET	Card Reset
25	A4	Address Bit 4	59	WAIT#	Extend Bus Cycle
26	A3	Address Bit 3	60	INPACK#	Input Port Acknowledge
27	A2	Address Bit 2	61	REG#	Register and I/O select enable
28	A1	Address Bit 1	62	SPKR#	Digital Audio Waveform
29	A0	Address Bit 0	63	STSCHG#	Card Status Changed
30	D0	Data Bit 0	64	D8	Data Bit 8
31	D1	Data Bit 1	65	D9	Data Bit 9
32	D2	Data Bit 2	66	D10	Data Bit 10
33	IOIS16#	IO Port is 16 bits	67	CD2#	Card Detect 2
34	GND	Ground	68	GND	Ground

Appendix B - Connector Drawings

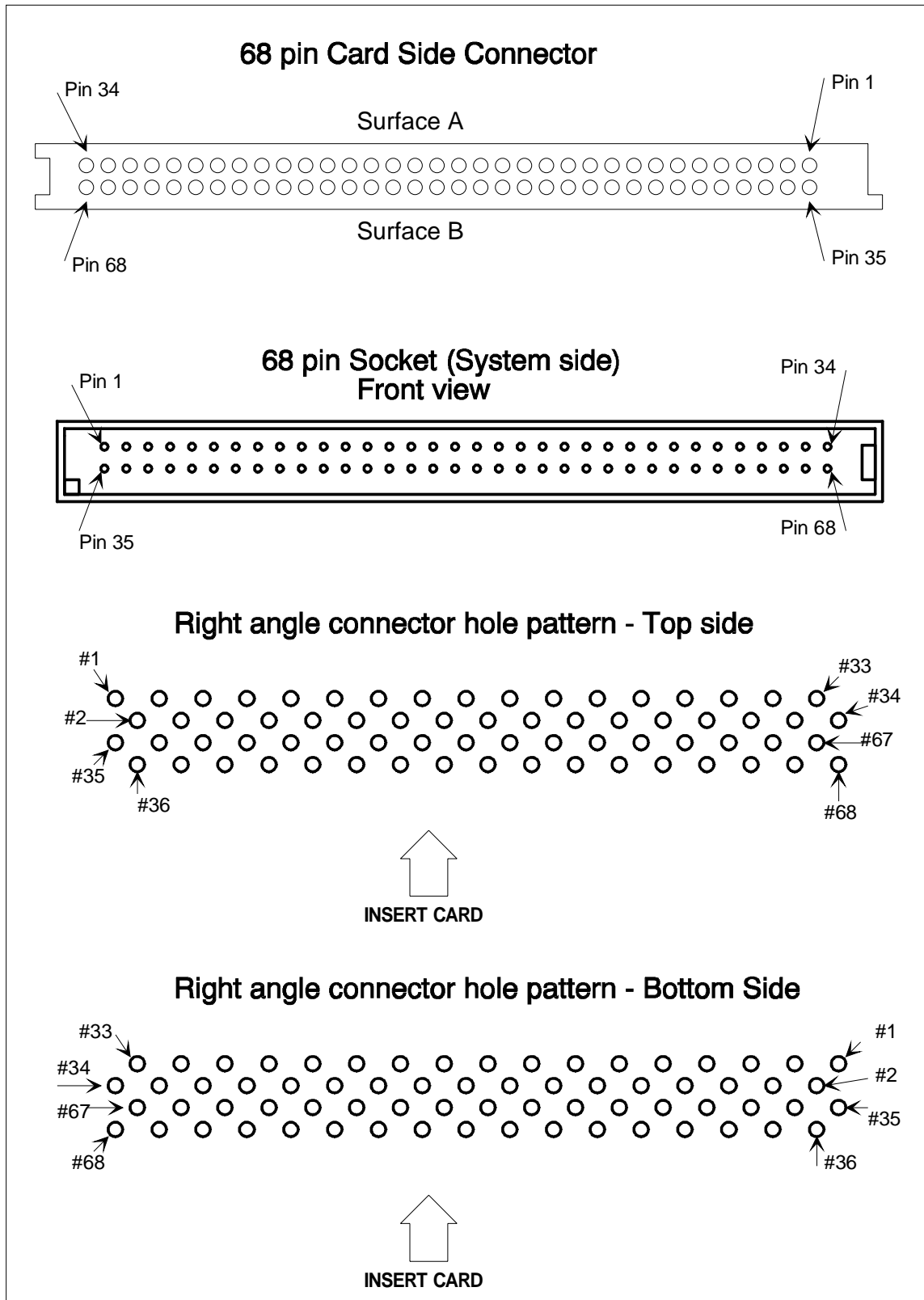

Appendix C - Testing the Texas Instruments CardBus Controllers

Texas Instrument's CardBus socket controllers support a serial controlled voltage switch to control the Vcc and Vpp to the PC Card socket. Three signal lines, DATA, CLOCK and LATCH are used to control the outputs of the voltage switch. On TI's PCI12xx demo boards, the CLOCK is configured as an output from the PCI12xx socket controller. However, in some implementations the CLOCK signal is externally generated and is an input to the PCI12xx socket controller. A control bit in PCI configuration space address 80H called P2CCLK (Bit 27) enables the voltage switch clock output (CLOCK) from the PCI12xx chip. CLOCK is derived from the PCI clock. In the original PCCtest software, this bit was set to enable CLOCK as an output. This was required for the PCI12xx demo boards. Designs that have an externally generated CLOCK will see two sources driving the CLOCK signal when running the PCCtest software.

The PCT170 software supports either an externally or internally generated voltage switch clock (CLOCK) signal. The user of the PCCtest software can specify this via a command line switch. By adding a "B" suffix to the "-B6x" switch, the user specifies that the voltage switch clock is internally generated from the PCI clock.

Command line for external voltage switch clock:

PCT170 -B65 -v -0

Command line for internally generated voltage switch clock:

PCT170 -B65B -v -0